



2026

**Introduction to
the Classification Technical Rules**

CONTENTS

1. LIST OF CLASSIFICATION TECHNICAL RULES	1
2. USER'S GUIDE TO CLASSIFICATION TECHNICAL RULES	7
2.1 General	7
2.2 User's Guide	7
2.3 Numbering System	7
2.4 Cross-Reference to Articles and Paragraphs	8
2.5 Cross-Reference to Figures and Tables	9
2.6 Units	9
3. CONTENTS OF CLASSIFICATION TECHNICAL RULES	11
3.1 Contents of Rules for the Classification of Steel Ships	11
3.2 Contents of Guidance Relating to the Rules for the Classification of Steel Ships	40
3.3 Contents of Rules for Offshore Structure	56
3.4 Contents of Guidance for Offshore Structures	61
3.5 Contents of Other Rules	68
3.6 Contents of Other Guidance	84
4. CONVERSION TABLE OF SI UNITS	117
5. LOAD LINE MARKS	119

1. LIST OF CLASSIFICATION TECHNICAL RULES

Rules for the Classification of Steel Ships	Guidance Relating to the Rules for the Classification of Steel Ships
<ul style="list-style-type: none"> - Pt 1 Classification and Surveys (K/E) (2026) - Pt 2 Materials and Welding (K/E) (2026) - Pt 3 Hull Structures (K/E) (2026) - Pt 4 Hull Equipment (K/E) (2026) - Pt 5 Machinery Installations (K/E) (2026) - Pt 6 Electrical Equipment and Control Systems (K/E) (2026) - Pt 7 Ships of Special Service (Ch1–Ch4, Ch7–Ch10) (K/E) (2026) - Pt 7 Ships of Special Service (Ch5, Ch6) (K/E) (2026) - Pt 8 Fire Protection and Fire Extinction (K/E) (2026) - Pt 9 Additional Installations (K/E) (2026) - Pt 10 Hull Structure and Equipment of Small Steel Ships (K/E) (2026) - Pt 11 Common Structural Rules for Bulk Carriers (K/E) (2014) - Pt 12 Common Structural Rules for Double Hull Oil Tankers (K/E) (2014) - Pt 13 Common Structural Rules for Bulk Carriers and Tankers (K/E) (2025) - Pt 14 Structural Rules for Container Ships (K/E) (2026) - Pt 15 Structural Rules for Membrane Type Liquefied Natural Gas Carriers (E) (2026) 	<ul style="list-style-type: none"> - Pt 1 Classification and Surveys (K/E) (2026) - Pt 2 Materials and Welding (K/E) (2026) - Pt 3 Hull Structures (K/E) (2026) - Pt 4 Hull Equipment (K/E) (2026) - Pt 5 Machinery Installations (K/E) (2026) - Pt 6 Electrical Equipment and Control Systems (K/E) (2026) - Pt 7 Ships of Special Service (Ch1–Ch4, Ch7–Ch10) (K/E) (2026) - Pt 7 Ships of Special Service (Ch5, Ch6) (K/E) (2026) - Pt 8 Fire Protection and Fire Extinction (K/E) (2026) - Pt 9 Additional Installations (K/E) (2026) - Pt 10 Hull Structure and Equipment of Small Steel Ships (K/E) (2026) - Pt 13 Common Structural Rules for Bulk Carriers and Tankers (K/E) (2024) - Pt 14 Structural Rules for Container Ships (K/E) (2026)

Rules for Offshore Structures	Guidance for Offshore Structures
<ul style="list-style-type: none"> - Rules for the Classification of Mobile Offshore Units (K/E) (2026) - Rules for the Classification of Mobile Offshore Drilling Units (K/E) (2026) - Rules for the Classification of Fixed Offshore Structures (K/E) (2023) 	<ul style="list-style-type: none"> - Guidance Relating to the Rules for the Classification of Mobile Offshore Units (K/E) (2026) - Guidance Relating to the Rules for the Classification of Mobile Offshore Drilling Units (K/E) (2026) - Guidance for Floating Offshore Production Units (K/E) (2023) - Guidance for Floating Liquefied Gas Storage and Regasification Units (K/E) (2019) - Guidance for Floating Liquefied Gas Production Units (K/E) (2019) - Guidance for OSV (K/E) (2026)

Other Rules	Other Guidances
<ul style="list-style-type: none"> - Rules for the Classification of Steel Barges (K/E) (2025) - Rules for the Classification of Underwater Vehicles (K/E) (2025) - Rules for the Classification of FRP Ships (K/E) (2014) - Rules for the Classification of Floating Docks (K/E) (2024) - Rules for the Classification of High Speed and Light Crafts (K/E) (2026) - Rules for the Classification of Ships Using Low-flashpoint Fuels (K/E) (2026) - Rules for the Towing Survey of Barges and Tugboats (K/E) (2022) - Rules for the Classification of Dredgers (K/E) (2023) 	<ul style="list-style-type: none"> - Guidance Relating to the Rules for the Classification of Steel Barges (K/E) (2025) - Guidance Relating to the Rules for the Classification of Underwater Vehicles (K/E) (2025) - Guidance Relating to the Rules for the Classification of FRP Ships (K/E) (2014) - Guidance Relating to the Rules for the Classification of Floating Docks (K/E) (2024) - Guidance Relating to the Rules for the Classification of High Speed and Light Craft (K/E) (2026) - Guidance Relating to the Rules for the Classification of Ships Using Low-flashpoint Fuels (K/E) (2026)

	Other Guidances
	<ul style="list-style-type: none"> - Guidance for Approval of Manufacturing Process and Type Approval, Etc. (K/E) (2026) - Guidance for Floating Structures (K/E) (2024) - Guidance for Freight Containers (K/E) (2026) - Guidance for Single Point Mooring (K/E) (2017) - Guidance for Ships Carrying CNG in Bulk (K/E) (2011) - Guidance for Recreational Crafts (K/E) (2026) - Guidance for WIG Craft (Wing-In-Ground Effect Craft) (K/E) (2019) - Guidance for Large Yachts (K/E) (2014) - Guidance for Fuel Cell Systems on Board of Ships (K/E) (2023) - Guidance for Ships for Navigation in Ice (K/E) (2025) - Guidance for Approval of Risk-based Ship Design (K/E) (2015) - Guidance for Strength Assessment of Membrane-Type LNG Tanks under Sloshing Loads (E) (2022) - Guidance for LNG Fuel Ready Ships (K/E) (2017) - Guidance on Strength Assessment of Containerships Considering the Whipping Effect (K/E) (2026) - Guidance for Structural Strength Assessment of Pump Tower of LNG Carrier (K/E) (2017) - Guidance for Noise and Vibration (K/E) (2020) - Guidance for Shiplift and Transfer Systems (K/E) (2017) - Guidance for Battery Systems on Board of Ships (K/E) (2026) - Guidance for Maritime Cyber Security System (K/E) (2026) - Guidance for Floating LNG Bunkering Terminal (K/E) (2018) - Guidance for approval of Service Suppliers (K/E) (2026) - Guidance for Autonomous Ships (K/E) (2026) - Guidance for DC Distribution Systems (K/E) (2025)

Other Rules	Other Guidances
	<ul style="list-style-type: none"> - Guidance for Software Conformity Certification (K/E) (2022) - Guidance for Conformity Certification of Maritime Equipment Cyber Security (K/E) (2023) - Guidance for Composite Propellers (K/E) (2021) - Guidance of Heat Transfer Analysis for Ships Carrying Liquefied Gases in Bulk/Ships Using Liquefied Gases as Fuels) (K/E) (2021) - Guidance for Integrated Software Process Management (K/E) (2021) - Guidance for Fatigue Strength Assessment Including Springing) (2020) - Guidance for Prevention Systems of Pollution from Ships (K/E) (2025) - Guidance for Radiated Noise from Ships (K/E) (2024) - Guidance for Remote Inspection Techniques (K/E) (2025) - Guidance for Remote Survey (K/E) (2023) - Guidance for Ships designed to Prevent the spread of Infectious Disease (K/E) (2023) - Guidance for Smart System (K/E) (2025) - Provisional Guidance for Ships of Less Than 24 Meters Using Liquefied Petroleum Gas as Fuel (K/E) (2023) - Guidance for Photovoltaic Systems Onboard Ships) (K/E) (2025) - Guidance for Cyber Resilience of Ships and Systems (K/E) (2026) - Guidance for Approval of Additive Manufacturing (3D Printing) (K/E) (2026) - Guidance for Anchor Handling Appliance (K/E) (2026)

2. USER'S GUIDE TO CLASSIFICATION TECHNICAL RULES

2.1 General

- 2.1.1 The purpose of this General has been prepared to introduce kinds, contents and user's guide for Classification Technical Rules published by Korean Register (hereinafter called "the Society") to users.
- 2.1.2 Classification Technical Rules published by the Society are grouped into "Rules" and "Guidances" which mean all rules for the classification of ships, offshore installations and related equipment, etc., and "Guidance Relating to the Rules", which is prepared with the intent of giving details as to the treatment of the various provisions for items required the unified interpretations and items not specified in the Rules. The list of Classification Technical Rules is given in 1.
- 2.1.3 Amendments to the Classification Technical Rules that need to be implemented prior to publishing the Classification Technical Rules are issued without a printed copy of the entire Rules or the Guidances.

2.2 User's Guide

2.2.1 Enforcement

Classification Technical Rules, in principle, shall come into force after 3 months from the approved date and "Amendments and Effective Date" is recorded at the beginning of each Classification Technical Rules for ready use.

2.2.2 Format

"Rules for Steel Ships" are composed of 15 kinds and "Guidances for Steel Ships" are composed of 12 kinds.

"Rules for Offshore Structures" are composed of 3 kinds and "Guidances for Offshore Structures" are composed of 6 kinds.

"Other Rules" are composed of 8 kinds and "Other Guidances" are composed of 6 kinds.

"Other Guidance" is composed of 40 kinds

2.3 Numbering System

2.3.1 "Rules for the Classification of Steel Ships" and "Guidance Relating to the Rules for the Classification of Steel Ships" (Part 1 to Part 10)

- (1) In principle, the text consists of Part, Chapter, Section, Article, Paragraph, Sub-paragraph, (A), (a) and (i).
- (2) An article consists of a section number and serial number, and the hundred means section number and the rest means serial number.
(e.g.) For eleventh article in **Section 2 ; 211.**

- (3) The number of a figure or a table consists of part, chapter and serial number in each chapter.

The figure number is placed in the center under the figure, and the table number is placed in the top left hand corner of the table.

(e.g.) For eighth figure in **Chapter 7** of **Part 3; Fig 3.7.8**

For second table in **Chapter 1** of **Part 5; Table 5.1.2**

2.3.2 "Rules for the Classification of Steel Ships" and "Guidance Relating to the Rules for the Classification of Steel Ships" (Part 13 to Part 15)

- (1) In principle, the text consists of Part, Sub-Part(for Part 13), Chapter, Section, Article, Sub-article, requirements.

- (2) An sub-article consists of a article number and serial number, and the requirements consists of sub-article and serial number.

(e.g.) For first article, first sub-article and first requirements : **1.1.1**

- (3) The number of a figure or a table consists of serial numbers in each section.
The figure number is placed below the figure, and the table number is placed at the top of the table.

(e.g.) For first figure in each Section : **Figure 1**

For first table in each Section : **Table 1**

2.3.23 Other Rules and Other Guidance

The same as **2.3.1**

2.3.34 Classification Rules other than 2.3.1, 2.3.2 and 2.3.23

- (1) In principle, the text consists of Chapter, Section, Article, Paragraph, Sub-paragraph, (A), (a) and (i).

- (2) The remainder are the same as those specified in **2.3.1**. The number of a figure or of a table consists of chapter and serial number in each chapter.

(e.g.) For ninth figure in **Chapter 3; Fig 3.9**

For tenth table in **Chapter 3; Table 3.10**.

2.4 Cross-Reference to Articles and Paragraphs

2.4.1 "Rules for the Classification of Steel Ships" and "Guidance Relating to the Rules for the Classification of Steel Ships"

- (1) Where a paragraph in any chapter is quoted from an other chapter in the same part, the chapter, relevant article and paragraph are written in sequence.

(e.g.) For rules: in **Ch 1, 201. 1 (1)**, or in **Ch 1, 201. 1 (1)** of the Guidance.

For guidances: in **Ch 1, 201.1(1)** of the Rules, or in **Ch 1, 201.1(1)** of the Guidance.

- (2) Where a paragraph in any part is quoted from an other part, the part, chapter, relevant article and paragraph are written in sequence.

(e.g.) For rules: in **Pt 1, Ch 1, 201. 1 (1)**, or in **Pt 1, Ch 1, 201. 1 (1)** of the Guidance.

For guidances: in **Pt 1, Ch 1, 201. 1 (1)** of the Rules, or in **Pt 1, Ch 1, 201. 1 (1)** of the Guidance.

2.4.2 Classification Rules other than 2.4.1

Where the contents of any rules are quoted in the rules other than **2.4.1**, the names of the rules, part, chapter, relevant article and paragraph are written.

(e.g.) Where **Pt 1, Ch 2, 202.** of "Rules for the Classification of Steel Ships" is quoted in "Rules for the Classification of Steel Barges"; **Pt 1, Ch 2, 202.** of **Rules for the Classification of Steel Ships**.

2.5 Cross-Reference to Figures and Tables

2.5.1 "Rules for the Classification of Steel Ships" and "Guidance relating to the Rules for the Classification of Steel Ships"

(1) Where a figure or a table in any chapter is quoted from an other chapter in the same part, the number of the figure (or the table) is written.

(e.g.) For rules: in **Fig 2.1.1** (or **Table 2.1.1**), or in **Fig 2.1.1** (or **Table 2.1.1**) of the Guidance.
For guidances: in **Fig 2.1.1** (or **Table 2.1.1**) of the Rules, or in **Fig 2.1.1** (or **Table 2.1.1**) of the Guidance.

(2) Where a figure or a table is quoted from an other part, the part and the number of the figure (or the table) are written.

(e.g.) For rules: in **Pt 2, Fig 2.1.1** (or **Table 2.1.1**), or in **Pt 2, Fig 2.1.1** (or **Table 2.1.1**) of the Guidance.

For guidances: in **Pt 2, Fig 2.1.1** (or **Table 2.1.1**) of the Rules, or in **Pt 2, Fig 2.1.1** (or **Table 2.1.1**) of the Guidance.

2.5.2 Classification Rules other than 2.5.1

Where a figure or a table of any rules is quoted in the rules other than **2.5.1**, the name of the rules, the part and the number of the figure (or the table) are written.

(e.g.) Where **Pt 3, Fig 3.3.1** (or **Table 3.3.1**) of "Rules for the Classification of Steel Ships" is quoted in "Rules for the Classification of Steel Barges": in **Pt 3, Fig 3.3.1** (or **Table 3.3.1**) of **Rules for the Classification of Steel Ships**.

2.6 Units

The SI-units (International System of Units) shown in **4.** are generally used in Classification Rules. However, the MKS-units (Metric System of Units) may be used together with SI-units, at the discretion of the Society. ↓

3. CONTENTS OF CLASSIFICATION TECHNICAL RULES

3.1 Contents of Rules for the Classification of Steel Ships

PART 1 CLASSIFICATION AND SURVEYS

CHAPTER 1 CLASSIFICATION

- Section 1 General
- Section 2 Character of Classification
- Section 3 Classification Survey during Construction
- Section 4 Classification Survey after Construction
- Section 5 Certificates and Reports
- Section 6 Application for Survey
- Section 7 Cooperation Duties of Owners
- Section 8 Competence, Duties of Surveyors and Responsibility and Scope of Classification
- Section 9 Suspension/Withdrawal of Class and Reclassification
- Section 10 Fees
- Section 11 Appeal on Disagreement
- Section 12 Related Regulations and Surveys
- Section 13 Classification of Other Installations or Equipment
- Section 14 External Audit
- Section 15 Miscellaneous

CHAPTER 2 PERIODICAL AND OTHER SURVEYS

- Section 1 General
- Section 2 Annual Survey
- Section 3 Intermediate Survey
- Section 4 Special Survey(Hull, Equipment and Fire-extinguishing Appliances)
- Section 5-1 Special Survey(Machinery, Electrical Installations and Additional Installations)
- Section 5-2 Special Survey(Additional Requirements to Ship Types)
- Section 6 Docking Survey
- Section 7 Surveys of Propeller Shaft and Stern Tube Shaft, Etc.
- Section 8 Boiler Survey
- Section 9 Continuous Survey of Machinery
- Section 10 Occasional Survey
- Section 11 Remote Survey
- Section 12 Alteration Survey
- Section 13 Survey of Ships Carrying Dangerous Goods and Other Special Cargoes
- Section 14 Additional Installations Survey
- Section 15 Hull Surveys for General Dry Cargo Ships
- Section 16 Hull Surveys for Liquefied Gas Carriers
- Section 17 Survey Requirements for Shell and Inner Doors, Etc. of RoRo Ships
- Section 18 Additional Requirements
- Section 19 Special Requirements for Ships Subject to Korean Ship Safety Act or Fishing Vessels Act

CHAPTER 3 HULL SURVEYS OF SHIPS SUBJECT TO THE ENHANCED SURVEY PROGRAMME

- Section 1 General
- Section 2 Bulk Carriers
- Section 3 Oil Tankers
- Section 4 Chemical Tankers
- Section 5 Double Hull Oil Tankers
- Section 6 Double Skin Bulk Carriers

PART 2 MATERIALS AND WELDING

CHAPTER 1 MATERIALS

- Section 1 General
- Section 2 Test Specimens and Testing Procedures
- Section 3 Rolled Steels
- Section 4 Steel Tubes and Pipes
- Section 5 Castings
- Section 6 Steel Forgings
- Section 7 Copper and Copper Alloy
- Section 8 Aluminium Alloys

CHAPTER 2 WELDING

- Section 1 General
- Section 2 Test Specimens and Testing Procedures
- Section 3 Welding work and Inspection
- Section 4 Welding Procedure Qualification Tests
- Section 5 Welders and Welder Performance Qualification Scheme
- Section 6 Welding Consumables

PART 3 HULL STRUCTURES

CHAPTER 1 GENERAL

- Section 1 Definitions
- Section 2 General
- Section 3 Approval of Plans and Documents
- Section 4 Materials
- Section 5 Weldings
- Section 6 Scantlings
- Section 7 Workmanship
- Section 8 Corrosion Protection Coating

CHAPTER 2 STEMS AND STERN FRAMES

- Section 1 Stems
- Section 2 Stern Frames

CHAPTER 3 LONGITUDINAL STRENGTH

- Section 1 General
- Section 2 Bending Strength
- Section 3 Shear Strength
- Section 4 Buckling Strength

CHAPTER 4 PLATE KEELS AND SHELL PLATINGS

- Section 1 General
- Section 2 Plate Keels
- Section 3 Shell Plating below Strength Deck
- Section 4 Special Requirements for Shell Plating
- Section 5 Side Plating in way of Superstructure
- Section 6 Compensation at ends of Superstructure
- Section 7 Local Compensation of Shell Plating

CHAPTER 5 DECKS

- Section 1 General
- Section 2 Effective Sectional Area of Strength Deck
- Section 3 Deck Plating
- Section 4 Wood Decks and Deck Compositions

CHAPTER 6 SINGLE BOTTOMS

- Section 1 General
- Section 2 Centre Keelsons
- Section 3 Side Keelsons
- Section 4 Floor Plates

CHAPTER 7 DOUBLE BOTTOMS

- Section 1 General
- Section 2 Centre Girders and Side Girders
- Section 3 Solid Floors
- Section 4 Bottom Longitudinals
- Section 5 Inner Bottom Plating, Margin Plates and Bottom Shell Plating
- Section 6 Hold Frame Brackets
- Section 7 Open Floors
- Section 8 Construction of Strengthened Bottom Forward

CHAPTER 8 FRAMES

- Section 1 General
- Section 2 Frame Spacing
- Section 3 Hold Frames
- Section 4 Side Longitudinals
- Section 5 Tween Deck Frames

CHAPTER 9 WEB FRAMES AND SIDE STRINGERS

- Section 1 General
- Section 2 Web Frames
- Section 3 Side Stringers

- Section 4 Side Transverse
- Section 5 Cantilever Beams

CHAPTER 10 BEAMS

- Section 1 General
- Section 2 Deck Load
- Section 3 Longitudinal Beams
- Section 4 Transverse Beams

CHAPTER 11 DECK GIRDERS

- Section 1 General
- Section 2 Longitudinal Deck Girders
- Section 3 Transverse Deck Girders
- Section 4 Deck Girders in Tanks
- Section 5 Hatch Side Girders
- Section 6 Hatch End Girders

CHAPTER 12 PILLARS

- Section 1 General
- Section 2 Scantling of Pillars

CHAPTER 13 ARRANGEMENTS TO RESIST PANTING

- Section 1 General
- Section 2 Arrangements to Resist Panting forward the Collision Bulkhead
- Section 3 Arrangements to Resist Panting abaft Aft-peak Bulkhead
- Section 4 Arrangements to Resist Panting between Both Peaks

CHAPTER 14 WATERTIGHT BULKHEADS

- Section 1 General
- Section 2 Arrangement of Watertight Bulkheads
- Section 3 Construction of Watertight Bulkheads
- Section 4 Watertight Doors

CHAPTER 15 DEEP TANKS

- Section 1 General
- Section 2 Bulkheads of Deep Tanks
- Section 3 Fittings of Deep Tanks
- Section 4 Welding of Corrugated Bulkheads

CHAPTER 16 SUPERSTRUCTURES

- Section 1 General
- Section 2 Superstructure End Bulkheads
- Section 3 Access Openings in Superstructure End Bulkheads

CHAPTER 17 DECKHOUSES

- Section 1 General
- Section 2 Construction

CHAPTER 18 MACHINERY SPACES AND ENGINE CASINGS

- Section 1 General
- Section 2 Main Engine Foundation
- Section 3 Construction of Boiler Rooms
- Section 4 Thrust Blocks and Foundations
- Section 5 Engine Casings

CHAPTER 19 TUNNELS AND TUNNEL RECESSES

- Section 1 General

PART 4 HULL EQUIPMENT

CHAPTER 1 RUDDERS

- Section 1 General
- Section 2 Rudder Force
- Section 3 Rudder Torque
- Section 4 Rudder Strength Calculation
- Section 5 Rudder Stocks
- Section 6 Rudder Plates, Rudder Frames and Rudder Main Pieces
- Section 7 Couplings between Rudder Stocks and Main Pieces
- Section 8 Pintles
- Section 9 Bearings of Rudder Stocks and Pintles
- Section 10 Rudder Accessories
- Section 11 Propeller Nozzles

CHAPTER 2 HATCHWAYS AND OTHER DECK OPENINGS

- Section 1 General
- Section 2 Design Load
- Section 3 Hatch cover strength criteria
- Section 4 Hatch Coamings strength criteria
- Section 5 Hatch cover details – Closing Arrangement, Securing Devices and Stoppers
- Section 6 Hatch ways closed by Portable Hatch Cover and weathertightened by Tarpaulins and Battens
- Section 7 Miscellaneous Openings

CHAPTER 3 BOW DOORS, SIDE AND STERN DOORS

- Section 1 Bow Doors and Inner Doors
- Section 2 Side and Stern Doors

CHAPTER 4 BULWARKS, FREEING PORTS, SIDE SCUTTLES, RECTANGULAR WINDOWS, SKYLIGHTS, VENTILATORS AND PERMANENT GANGWAYS

- Section 1 Bulwarks and Guardrails
- Section 2 Freeing Ports
- Section 3 Side Scuttles, Rectangular Windows and Skylights
- Section 4 Ventilators
- Section 5 Permanent Gangways

CHAPTER 5 MASTS AND DERRICK POSTS – Void

CHAPTER 6 CEILINGS AND SPARRINGS – Void

CHAPTER 7 CEMENTING AND PAINTING – Void

CHAPTER 8 EQUIPMENT NUMBER AND EQUIPMENT

- Section 1 General
- Section 2 Equipment Number
- Section 3 Anchors
- Section 4 Chains
- Section 5 Steel Wire Ropes
- Section 6 Fibre Ropes
- Section 7 Hatch Tarpaulins
- Section 8 Side Scuttles
- Section 9 Rectangular Windows

CHAPTER 9 STRENGTH AND SECURING OF SMALL HATCHES, FITTINGS AND EQUIPMENT ON THE FORE DECK

- Section 1 Application and Implementation
- Section 2 Strength and Securing of Small Hatches on the Exposed Fore Deck
- Section 3 Strength Requirements for Fore Deck Fittings and Equipment

CHAPTER 10 SHIPBOARD EQUIPMENT, FITTINGS AND SUPPORTING HULL STRUCTURES ASSOCIATED WITH TOWING AND MOORING

- Section 1 Definitions and Scope of Application
- Section 2 Towing and Mooring

CHAPTER 11 ACCESS TO AND WITHIN SPACES IN, AND FORWARD OF, THE CARGO AREA OF OIL TANKERS AND BULK CARRIERS

- Section 1 General
- Section 2 Technical Provisions for Means of Access for Inspections

PART 5 MACHINERY INSTALLATIONS

CHAPTER 1 GENERAL

- Section 1 General
- Section 2 Plans and Documents
- Section 3 Tests and Inspections
- Section 4 Spare Parts and Tools

CHAPTER 2 MAIN AND AUXILIARY ENGINES

- Section 1 General
- Section 2 Reciprocating Internal Combustion Engines
- Section 3 Steam Turbines
- Section 4 Gas Turbines

CHAPTER 3 PROPULSION SHAFTING AND POWER TRANSMISSION SYSTEMS

- Section 1 General
- Section 2 Shaftings
- Section 3 Propellers
- Section 4 Power Transmission Systems
- Section 5 Water-jet propulsion systems
- Section 6 Azimuth thrusters

CHAPTER 4 TORSIONAL VIBRATION OF SHAFTINGS

- Section 1 General
- Section 2 Allowable Limit of Vibration Stresses

CHAPTER 5 BOILERS AND PRESSURE VESSELS

- Section 1 Boilers
- Section 2 Thermal Oil Heaters
- Section 3 Pressure Vessels
- Section 4 Welding for Boilers and Pressure Vessels

CHAPTER 6 AUXILIARIES AND PIPING ARRANGEMENT

- Section 1 General
- Section 2 Air Pipes, Overflow Pipes and Sounding Devices
- Section 3 Ship-side Valves and Overboard Discharge
- Section 4 Bilge and Ballast System
- Section 5 Feed Water and Condensate System for Boiler
- Section 6 Steam and Exhaust Gas Piping
- Section 7 Cooling System
- Section 8 Lubricating Oil System
- Section 9 Fuel Oil System
- Section 10 Thermal Oil System
- Section 11 Compressed Air System
- Section 12 Refrigerating Machinery
- Section 13 Hydraulic System
- Section 14 Tests and Inspections

CHAPTER 7 STEERING GEARS

- Section 1 General
- Section 2 Performance and Arrangement
- Section 3 Controls
- Section 4 Materials, Constructions and Strength
- Section 5 Testing
- Section 6 Additional Requirements Concerning Tankers of 10,000 Gross Tonnage and Upwards and Other Ships of 70,000 Gross Tonnage and Upwards

CHAPTER 8 WINDLASSES AND MOORING WINCHES

- Section 1 General
- Section 2 Windlasses

Section 3 Mooring Winches

PART 6 ELECTRICAL EQUIPMENT AND CONTROL SYSTEMS

CHAPTER 1 ELECTRICAL EQUIPMENT

- Section 1 General
- Section 2 System Design
- Section 3 Rotating Machinery
- Section 4 Switchboards, Section Boards and Distribution Boards
- Section 5 Cables
- Section 6 Transformers for Power and Lighting
- Section 7 Controlgears for Motors and Magnetic Brakes
- Section 8 Fuses, Circuit-breakers and Electromagnetic Contactors
- Section 9 Explosion-protected Electrical Equipment
- Section 10 Lighting Fittings, Heating Appliances, Wiring Accessories and Miscellaneous Equipment
- Section 11 Internal Communications
- Section 12 Semi-Conductor Converters
- Section 13 Accumulator Batteries
- Section 14 Lightning Conductors
- Section 15 High Voltage Electrical Installations
- Section 16 Electric Propulsion Unit
- Section 17 Tests after Installation on Board
- Section 18 Spare Parts, Tools and Instruments

CHAPTER 2 CONTROL SYSTEMS

- Section 1 General
- Section 2 System and Control
- Section 3 Tests
- Section 4 Computer Based Systems

PART 7 SHIPS OF SPECIAL SERVICE

CHAPTER 1 OIL TANKERS

- Section 1 General
- Section 2 Hatchways, Gangways and Freeing Arrangements
- Section 3 Longitudinal Frames and Beams in Cargo Oil Spaces
- Section 4 Girders, Transverses and Cross Ties in Cargo Oil Spaces
- Section 5 Bulkheads in Cargo Oil Spaces
- Section 6 Relative Deformation of Wing Tanks
- Section 7 Welding
- Section 8 Supplementary Provisions for Tankers Having Longitudinal Bulkhead at Centre Line Only
- Section 9 Special Requirements for Wing Tanks at Fore Parts
- Section 10 Piping Systems and Venting Systems for Oil Tankers
- Section 11 Electrical Equipment

CHAPTER 2 ORE CARRIERS

- Section 1 General
- Section 2 Double bottoms
- Section 3 Wing Tanks or Void Spaces
- Section 4 Transverse Bulkheads and Stools in Ore Holds
- Section 5 Relative deformation of wing tanks
- Section 6 Decks and Miscellaneous
- Section 7 Ore/Oil Carriers

CHAPTER 3 BULK CARRIERS

- Section 1 General
- Section 2 Harmonized Notations and Corresponding Design Loading Conditions
- Section 3 Double Bottoms
- Section 4 Hopper Tanks
- Section 5 Topside Tanks
- Section 6 Transverse Bulkheads and Stools
- Section 7 Hold Frames
- Section 8 Decks and Shell Platings
- Section 9 <Void>
- Section 10 Longitudinal Strength of Hull Girder in Flooded Condition for Bulk Carriers
- Section 11 Evaluation of Allowable Hold Loading for Bulk Carriers Considering Hold Flooding
- Section 12 Evaluation of Scantlings of Corrugated Transverse Watertight Bulkheads in Bulk Carriers Considering Hold Flooding
- Section 13 Requirements for the Fitting of a Forecastle for Bulk Carriers, Ore Carriers and Combination Carriers
- Section 14 Water Level Detection & Alarm and Drainage & Pumping Systems for Bulk Carriers and Single Hold Cargo Ships
- Section 15 Supplementary Provisions for Carriage of Liquid in Holds
- Section 16 Electrical Equipment of Coal Carriers
- Section 17 Renewal Criteria for Side Shell Frames and Brackets in Single Side Skin Bulk Carriers and Single Side Skin OBO Carriers
- Section 18 Cargo Hatch Cover Securing Arrangements

CHAPTER 4 CONTAINER SHIPS

- Section 1 General
- Section 2 Longitudinal Strength
- Section 3 Double Bottoms
- Section 4 Double Side Construction
- Section 5 Transverse Bulkheads
- Section 6 Deck Construction
- Section 7 Breakwater
- Section 8 Tug Pushing Area
- Section 9 Strength at Large Flare Location
- Section 10 Freight Container Securing Arrangement
- Section 11 Welding

CHAPTER 5 SHIPS CARRYING LIQUEFIED GASES IN BULK (Separate Publication)

- Section 1 General
- Section 2 Ship Survival Capability and Location of Cargo Tanks
- Section 3 Ship Arrangements
- Section 4 Cargo Containment
- Section 5 Process Pressure Vessels and Liquid, Vapour and Pressure Piping Systems
- Section 6 Materials of Construction and Quality Control
- Section 7 Cargo Pressure/Temperature Control
- Section 8 Vent Systems for Cargo Containment
- Section 9 Cargo Containment System Atmosphere Control
- Section 10 Electrical Installations
- Section 11 Fire Protection and Fire Extinction
- Section 12 Mechanical Ventilation in the Cargo Area
- Section 13 Instrumentation and Automation Systems
- Section 14 Personnel Protection
- Section 15 Filling Limits for Cargo Tanks
- Section 16 Use of Cargo as Fuel
- Section 17 Special Requirements
- Section 18 Operating Requirements
- Section 19 Summary of Minimum Requirements

CHAPTER 6 SHIPS CARRYING DANGEROUS CHEMICALS IN BULK (Separate Publication)

- Section 1 General
- Section 2 Ship Survival Capability and Location of Cargo Tanks
- Section 3 Ship Arrangements
- Section 4 Cargo Containment
- Section 5 Cargo Transfer
- Section 6 Materials of Construction
- Section 7 Cargo Temperature Control
- Section 8 Cargo Tank Venting and Gas-freeing Arrangements
- Section 9 Environmental Control
- Section 10 Electrical Installations
- Section 11 Fire Protection and Fire Extinction
- Section 12 Mechanical Ventilation in the Cargo Area
- Section 13 Instrumentation
- Section 14 Personnel Protection
- Section 15 Special Requirements
- Section 16 Operational Requirements
- Section 17 Summary of Minimum Requirements
- Section 18 List of Chemicals to which this Chapter does not apply
- Section 19 Index of Products Carried in Bulk
- Section 20 Transport of Liquid Chemical Wastes
- Section 21 Criteria for assigning carriage requirements for products subject to the IBC Code

CHAPTER 7 CAR FERRIES AND ROLL-ON/ROLL-OFF SHIPS

- Section 1 General
- Section 2 Longitudinal Strength
- Section 3 Deck Structure
- Section 4 Electrical Equipment of Automobile Carriers

CHAPTER 8 OFFSHORE SUPPLY SHIPS

- Section 1 General
- Section 2 Longitudinal Strength
- Section 3 Shell Plating
- Section 4 Deck Plating
- Section 5 Framing
- Section 6 Superstructures and Deckhouses
- Section 7 Watertight Bulkhead Doors
- Section 8 Engine Exhaust Outlets

CHAPTER 9 TUGS

- Section 1 General
- Section 2 Longitudinal Strength
- Section 3 Single Bottoms
- Section 4 Panting and Strengthening of Bottom Forward
- Section 5 Machinery Casings
- Section 6 Towing Arrangements
- Section 7 Fenders
- Section 8 Towing Winch Emergency Release Systems

CHAPTER 10 DOUBLE HULL TANKER

- Section 1 General
- Section 2 Bulkhead Plating
- Section 3 Longitudinals and Stiffeners
- Section 4 Girders
- Section 5 Structural Details
- Section 6 Special Requirements for Corrosion
- Section 7 Special Requirements for Forward Wing Tanks
- Section 8 Special Requirements for Tankers with Mid-deck
- Section 9 Special Requirements for Hatchways and Permanent Gangway
- Section 10 Welding

PART 8 FIRE PROTECTION AND FIRE EXTINCTION

CHAPTER 1 GENERAL

- Section 1 General

CHAPTER 2 PROBABILITY OF IGNITION

- Section 1 Arrangements for Oil Fuel, Lubrication Oil and Other Flammable Oils
- Section 2 Arrangements for Gaseous Fuel for Domestic Purpose

- Section 3 Miscellaneous Items of Ignition Sources And Ignitability
- Section 4 Cargo Areas of Tankers

CHAPTER 3 FIRE GROWTH POTENTIAL

- Section 1 Control of Air Supply And Flammable Liquid to The Spaces
- Section 2 Fire Protection Materials

CHAPTER 4 SMOKE GENERATION POTENTIAL AND TOXICITY

- Section 1 Paints, Varnishes And Other Finishes
- Section 2 Primary Deck Coverings

CHAPTER 5 DETECTION AND ALARM

- Section 1 General
- Section 2 Protection of Machinery Spaces
- Section 3 Protection of Accommodation And Service Spaces And Control Stations
- Section 4 Protection of Cargo Spaces in Passenger Ships
- Section 5 Manually Operated Call Points
- Section 6 Fire Patrols in Passenger Ships
- Section 7 Fire Alarm Signalling Systems in Passenger Ships
- Section 8 Protection of cabin balconies on passenger ships

CHAPTER 6 CONTROL OF SMOKE SPEED

- Section 1 Protection of Control Stations Outside Machinery Space
- Section 2 Release of Smoke from Machinery Spaces
- Section 3 Draft Stops
- Section 4 Smoke Extraction Systems in Atriums of Passenger Ships

CHAPTER 7 CONTAINMENT OF FIRE

- Section 1 Thermal And Structural Boundaries
- Section 2 Penetration in Fire-resisting Divisions And Prevention of Heat Transmission
- Section 3 Protection of Openings in Fire-resisting Divisions
- Section 4 Protection of Openings In Machinery Space Boundaries
- Section 5 Protection of Cargo Space Boundaries
- Section 6 Ventilation Systems

CHAPTER 8 FIRE FIGHTING

- Section 1 Water Supply System
- Section 2 Portable Fire Extinguishers
- Section 3 Fixed Fire-extinguishing Systems
- Section 4 Fire Extinguishing Arrangements In Machinery Spaces
- Section 5 Fire-extinguishing Arrangements In Control Stations, Accommodation And Service Spaces
- Section 6 Fire-extinguishing Arrangements In Cargo Spaces
- Section 7 Cargo Tank Protection
- Section 8 Protection of Cargo Pump Room
- Section 9 Fire-fighter's Outfit
- Section 10 Fire-extinguishing media restrictions

CHAPTER 9 STRUCTURAL INTEGRITY

- Section 1 Material
- Section 2 Structure of aluminium alloy
- Section 3 Machinery Spaces of Category A
- Section 4 Materials of Overboard Fittings
- Section 5 Protection of Cargo Tank Structure Against Pressure Or Vacuum In Tankers

CHAPTER 10 ESCAPE

- Section 1 Notification of crew and passengers
- Section 2 Means of escape

CHAPTER 11 HELICOPTER FACILITIES

- Section 1 Application
- Section 2 Structure
- Section 3 Means of Escape
- Section 4 Fire-fighting Appliances
- Section 5 Drainage Facilities
- Section 6 Helicopter Refueling And Hanger Facilities
- Section 7 Operations Manual And Fire-fighting Service

CHAPTER 12 CARRIAGE OF DANGEROUS GOODS

- Section 1 General Requirements
- Section 2 Special Requirements
- Section 3 Document of Compliance

CHAPTER 13 PROTECTION OF VEHICLE, SPECIAL CATEGORY, OPEN AND CLOSED RO-RO SPACES, AND WEATHER DECKS INTENDED FOR THE CARRIAGE OF VEHICLES

- Section 1 General Requirements
- Section 2 Precaution against ignition of flammable vapours in closed vehicle spaces closed ro-ro spaces and special category spaces
- Section 3 Detection and alarm
- Section 4 Structure protection
- Section 5 Fire-extinction
- Section 6 Decision-making
- Section 7 Requirements for vehicle carriers carrying motor vehicles with compressed hydrogen or natural gas in their tanks for their own propulsion as cargo

CHAPTER 14 SAFETY RETURN TO PORT SYSTEM ON PASSENGER SHIPS

- Section 1 General

PART 9 ADDITIONAL INSTALLATIONS

CHAPTER 1 CARGO REFRIGERATING INSTALLATIONS

- Section 1 General
- Section 2 Surveys
- Section 3 Refrigerating Machinery

- Section 4 Special Requirements for Refrigerating Machinery Using Ammonia as Refrigerant
- Section 5 Refrigerated Chambers
- Section 6 Tests
- Section 7 Loading Port Surveys

CHAPTER 2 CARGO HANDLING APPLIANCES

- Section 1 General
- Section 2 Surveys
- Section 3 Derrick Systems
- Section 4 Cranes
- Section 5 Cargo Fittings
- Section 6 Loose Gear
- Section 7 Machinery, Electrical Installations and Control Engineering Systems
- Section 8 Cargo Lifts and Cargo Ramps
- Section 9 Certification, Marking and Documentation

CHAPTER 3 AUTOMATIC AND REMOTE CONTROL SYSTEMS

- Section 1 General
- Section 2 Surveys of Automatic and Remote Control Systems
- Section 3 Centralized Monitoring and Control Systems for Main Propulsion and Essential Auxiliary Machinery
- Section 4 Operating Systems for Periodically Unattended Machinery Spaces
- Section 5 Specific Automatic Equipment

CHAPTER 4 DYNAMIC POSITIONING SYSTEMS(DP SYSTEMS)

- Section 1 General
- Section 2 Requirements of Dynamic Positioning Systems
- Section 3 Testing and Inspection

CHAPTER 5 NAVIGATION BRIDGE SYSTEMS

- Section 1 General
- Section 2 Surveys of Navigation Bridge Systems
- Section 3 Bridge Layouts and Bridge Working Environments
- Section 4 Navigational Equipment
- Section 5 Accident Prevention Systems
- Section 6 Bridge Work Assist Systems

CHAPTER 6 HULL MONITORING SYSTEMS

- Section 1 General
- Section 2 System Requirements
- Section 3 Approval for Plans and Documents, Installation and Installation Survey
- Section 4 Periodical Survey

CHAPTER 7 DIVING SYSTEMS

- Section 1 General
- Section 2 Classification Survey
- Section 3 Inspection and Testing

- Section 4 Design and Construction
- Section 5 PVHO
- Section 6 Deck Decompression Chambers and divers transfer system
- Section 7 Life Support System
- Section 8 Electrical, Control and Communication Systems
- Section 9 Fire Protection, Extinction and Detection
- Section 10 Launch and Recovery System
- Section 11 Hyperbaric Rescue Unit

CHAPTER 8 ONSHORE POWER SUPPLY SYSTEM

- Section 1 General
- Section 2 Requirements of HVSC systems
- Section 3 Testing and Inspection

CHAPTER 9 CARGO VAPOUR EMISSION CONTROL SYSTEMS

- Section 1 General
- Section 2 Requirements for VEC1 Notation
- Section 3 Requirements for VEC2 Notation
- Section 4 Requirements for VECL Notation
- Section 5 Surveys

CHAPTER 10 BALLAST WATER MANAGEMENT

- Section 1 General
- Section 2 Ballast Water Exchange Systems
- Section 3 Ballast Water Management Systems
- Section 4 Installation of BWMS on-board ships

PART 10 HULL STRUCTURE AND EQUIPMENT OF SMALL STEEL SHIPS

CHAPTER 1 GENERAL

- Section 1 Definitions
- Section 2 General
- Section 3 Materials, Welding and Construction

CHAPTER 2 STEMS AND STERN FRAMES

- Section 1 Stems
- Section 2 Stern Frames

CHAPTER 3 LONGITUDINAL STRENGTH

- Section 1 General
- Section 2 Bending Strength
- Section 3 Buckling Strength

CHAPTER 4 PLATE KEELS AND SHELL PLATINGS

- Section 1 General
- Section 2 Plate Keels
- Section 3 Shell Plating for Midship Part of Ship

- Section 4 Shell Plating for End Parts
- Section 5 Side Plating in way of Superstructure
- Section 6 Local Compensation of Shell Plating

CHAPTER 5 DECKS

- Section 1 General
- Section 2 Effective Sectional Area of Strength Deck
- Section 3 Deck Plating

CHAPTER 6 SINGLE BOTTOMS

- Section 1 General
- Section 2 Centre Keelsons
- Section 3 Side Keelsons
- Section 4 Floor Plates
- Section 5 Longitudinals
- Section 6 Strengthened Bottom Forward

CHAPTER 7 DOUBLE BOTTOMS

- Section 1 General
- Section 2 Centre Girders
- Section 3 Side Girders
- Section 4 Solid Floors
- Section 5 Bottom Longitudinals
- Section 6 Inner Bottom Plating and Margin Plates
- Section 7 Hold Frame Brackets
- Section 8 Open Floors
- Section 9 Construction of Strengthened Bottom Forward

CHAPTER 8 FRAMES

- Section 1 General
- Section 2 Frame Spacing
- Section 3 Transverse Hold Frames
- Section 4 Side Longitudinals
- Section 5 Tween Deck Frames
- Section 6 Frames in Both Peaks

CHAPTER 9 CANTILEVER BEAM CONSTRUCTION

- Section 1 Cantilever Beams
- Section 2 Web Frames
- Section 3 Connection of Cantilever Beams to Web Frames

CHAPTER 10 BEAMS

- Section 1 General
- Section 2 Deck Load
- Section 3 Longitudinal Beams
- Section 4 Transverse Beams
- Section 5 Beams on Bulkhead Recesses and Others

- Section 6 Beams on the Top of Deep Tanks
- Section 7 Deck Beams Supporting Specially Heavy Loads
- Section 8 Beams on Deck Carrying Unusual Cargoes

CHAPTER 11 DECK GIRDERS

- Section 1 General
- Section 2 Longitudinal Deck Girders
- Section 3 Transverse Deck Girders
- Section 4 Deck Girders in Tanks
- Section 5 Hatch Side Girders
- Section 6 Hatch End Girders

CHAPTER 12 PILLARS

- Section 1 General
- Section 2 Scantling of Pillars

CHAPTER 13 ARRANGEMENTS TO RESIST PANTING

- Section 1 General
- Section 2 Arrangements to resist Panting Forward the Collision Bulkhead
- Section 3 Arrangements to resist Panting Aft Aft Peak Bulkhead

CHAPTER 14 WATERTIGHT BULKHEADS

- Section 1 Arrangement
- Section 2 Construction
- Section 3 Watertight Doors

CHAPTER 15 DEEP TANKS

- Section 1 General
- Section 2 Bulkheads of Deep Tanks
- Section 3 Fittings of Deep Tanks
- Section 4 Welding of Corrugated bulkheads

CHAPTER 16 SUPERSTRUCTURES AND DECKHOUSES

- Section 1 General
- Section 2 Construction
- Section 3 Access Openings in Superstructure End Bulkheads

CHAPTER 17 MACHINERY SPACES AND ENGINE CASINGS

- Section 1 General
- Section 2 Main Engine Foundations
- Section 3 Construction of Boiler Rooms
- Section 4 Thrust Blocks and Foundations
- Section 5 Machinery Space Openings

CHAPTER 18 TUNNELS AND TUNNEL RECESSES

- Section 1 General

CHAPTER 19 HATCHWAYS AND OTHER DECK OPENINGS

Section 1 General

CHAPTER 20 BOW DOORS, SIDE AND STERN DOORS

Section 1 Bow Doors and Inner Doors

Section 2 Side and Stern Door

CHAPTER 21 BULWARKS FREEING PORTS, SIDE SCUTTLES, VENTILATORS AND PERMANENT GANGWAYS

Section 1 Bulwarks

Section 2 Freeing Ports

Section 3 Side Scuttles

Section 4 Ventilators

Section 5 Permanent Gangways

CHAPTER 22 EQUIPMENT NUMBER AND EQUIPMENT

Section 1 General

Section 2 Equipment Number

Section 3 Shipboard Fittings and Supporting Hull Structures associated with Towing and Mooring

CHAPTER 23 OIL TANKERS

Section 1 General

Section 2 Hatchways, Gangways and Freeing Arrangements

Section 3 Longitudinal Frames and Beams in Cargo Oil Spaces

Section 4 Girders and Transverses in Cargo Oil Spaces

Section 5 Trunks

Section 6 Bulkheads in Cargo Oil Space

CHAPTER 24 DOUBLE HULL TANKERS

Section 1 General

Section 2 Bulkhead Plating

Section 3 Frames, Stiffeners and Longitudinal Beams

Section 4 Structural Members in Double Bottoms

Section 5 Structural Members in Double Side Hull

Section 6 Girders and Transverses in Cargo Oil Tanks and Deep Tanks

Section 7 Strengthened Bottom Forward

Section 8 Structural Details

Section 9 Special Requirements for Corrosion

Section 10 Special Requirements for Hatchways and Permanent Gangways

PART 11 COMMON STRUCTURAL RULES FOR BULK CARRIERS

CHAPTER 1 GENERAL PRINCIPLES

Section 1 Application

Section 2 Verification of Compliance

Section 3 Functional Requirements

Section 4 Symbols and Definitions

CHAPTER 2 GENERAL ARRANGEMENT DESIGN

- Section 1 Subdivision Arrangement
- Section 2 Compartment Arrangement
- Section 3 Access Arrangement

CHAPTER 3 STRUCTURAL DESIGN PRINCIPLES

- Section 1 Material
- Section 2 Net Scantling Approach
- Section 3 Corrosion Additions
- Section 4 Limit States
- Section 5 Corrosion Protection
- Section 6 Structural Arrangement Principles

CHAPTER 4 DESIGN LOADS

- Section 1 General
- Section 2 Ship Motions and Accelerations
- Section 3 Hull Girder Loads
- Section 4 Load Cases
- Section 5 External Pressures
- Section 6 Internal Pressures and Forces
- Section 7 Loading Conditions
- Section 8 Loading Manuel & Loading Instrument

〈Appendix〉

- Appendix 1 Hold Mass Curves
- Appendix 2 Standard Loading Conditions for Direct Strength Analysis
- Appendix 3 Standard Loading Condition for Fatigue Assessment

CHAPTER 5 HULL GIRDER STRENGTH

- Section 1 Yielding Check
- Section 2 Ultimate Strength Check

〈Appendix〉

- Appendix 1 Hull Girder Ultimate Strength

CHAPTER 6 HULL SCANTLINGS

- Section 1 Plating
- Section 2 Ordinary Stiffeners
- Section 3 Buckling & Ultimate Strength of Ordinary Stiffeners and Stiffened Panels
- Section 4 Primary Supporting Members

〈Appendix〉

- Appendix 1 Buckling & Ultimate Strength

CHAPTER 7 DIRECT STRENGTH ANALYSIS

- Section 1 Direct Strength Assessment of the Primary Supporting Members
- Section 2 Global Strength FE Analysis of Cargo Hold Structures
- Section 3 Detail Stress Assessment

Section 4 Hot Spot Stress Analysis for Fatigue Strength Assessment

<Appendix>

Appendix 1 Longitudinal Extent of the Finite Element Models

Appendix 2 Displacement Based Buckling Assessment in Finite Element Analysis

CHAPTER 8 FATIGUE CHECK OF STRUCTURAL DETAILS

Section 1 General Consideration

Section 2 Fatigue Strength Assessment

Section 3 Stress Assessment of Primary Members

Section 4 Stress Assessment of Stiffeners

Section 5 Stress Assessment of Hatch Corners

<Appendix>

Appendix 1 Cross Sectional Properties for Torsion

CHAPTER 9 OTHER STRUCTURES

Section 1 Fore Part

Section 2 Aft Part

Section 3 Machinery Space

Section 4 Superstructures and Deckhouses

Section 5 Hatch Covers

Section 6 Arrangement of Hull and Superstructure Openings

CHAPTER 10 HULL OUTFITTING

Section 1 Rudder and Maneuvering Arrangement

Section 2 Bulwarks and Guard Rails

Section 3 Equipment

CHAPTER 11 CONSTRUCTION AND TESTING

Section 1 Construction

Section 2 Welding

Section 3 Testing of Compartments

CHAPTER 12 ADDITIONAL CLASS NOTATIONS

Section 1 GRAB Additional Class Notation

CHAPTER 13 SHIPS IN OPERATION, RENEWAL CRITERIA

Section 1 Maintenance of Class

Section 2 Thickness Measurements and Acceptance Criteria

PART 12 COMMON STRUCTURAL RULES FOR DOUBLE HULL OIL TANKERS

CHAPTER 1 INTRODUCTION

Section 1 Introduction to Common Structural Rules for Oil Tankers

CHAPTER 2 RULE PRINCIPLES

Section 1 Introduction

- Section 2 General Assumptions
- Section 3 Design Basis
- Section 4 Design Principles
- Section 5 Application of Principles

CHAPTER 3 RULE APPLICATION

- Section 1 Notations
- Section 2 Documentation, Plans and Data Requirements
- Section 3 Scope of Approval
- Section 4 Equivalence Procedure
- Section 5 Calculation and Evaluation of Scantling Requirements

CHAPTER 4 BASIC INFORMATION

- Section 1 Definitions
- Section 2 Structural Idealisation
- Section 3 Structure Design Details

CHAPTER 5 STRUCTURAL ARRANGEMENT

- Section 1 General
- Section 2 Watertight Subdivision
- Section 3 Double Hull Arrangement
- Section 4 Separation of Spaces
- Section 5 Access Arrangements

CHAPTER 6 MATERIALS AND WELDING

- Section 1 Steel Grades
- Section 2 Corrosion Protection Including Coatings
- Section 3 Corrosion Additions
- Section 4 Fabrication
- Section 5 Weld Design and Dimensions

CHAPTER 7 LOADS

- Section 1 Introduction
- Section 2 Static Load Components
- Section 3 Dynamic Load Components
- Section 4 Sloshing and Impact Loads
- Section 5 Accidental Loads
- Section 6 Combination of Loads

CHAPTER 8 SCANTLING REQUIREMENTS

- Section 1 Longitudinal Strength
- Section 2 Cargo Tank Region
- Section 3 Forward of the Forward Cargo Tank
- Section 4 Machinery Space
- Section 5 Aft End
- Section 6 Evaluation of Structure for Sloshing and Impact Loads
- Section 7 Application of Scantling Requirements to Other Structure

CHAPTER 9 DESIGN VERIFICATION

- Section 1 Hull Girder Ultimate Strength
- Section 2 Strength Assessment (FEM)
- Section 3 Fatigue Strength

CHAPTER 10 BUCKLING AND ULTIMATE STRENGTH

- Section 1 General
- Section 2 Stiffness and Proportions
- Section 3 Prescriptive Buckling Requirements
- Section 4 Advanced Buckling Analyses

CHAPTER 11 GENERAL REQUIREMENTS

- Section 1 Hull Openings and Closing Arrangements
- Section 2 Crew Protection
- Section 3 Support Structure and Structural Appendages
- Section 4 Equipment
- Section 5 Testing Procedures

CHAPTER 12 SHIP IN OPERATION RENEWAL CRITERIA

- Section 1 Allowable Thickness Diminution for Hull Structure

⟨APPENDIX⟩

APPENDIX A HULL GIRDER ULTIMATE STRENGTH

- Section 1 General
- Section 2 Calculation of Hull Girder Ultimate Capacity
- Section 3 Alternative Methods

APPENDIX B STRUCTURAL STRENGTH ASSESSMENT

- Section 1 General
- Section 2 Cargo Tank Structural Strength Analysis
- Section 3 Local Fine Mesh Structural Strength Analysis
- Section 4 Evaluation of Hot Spot Stress for Fatigue Analysis

APPENDIX C FATIGUE STRENGTH ASSESSMENT

- Section 1 Nominal Stress Approach
- Section 2 Hot Spot Stress (FE Based) Approach

APPENDIX D BUCKLING STRENGTH ASSESSMENT

- Section 1 Advanced Buckling Analysis
- Section 2 Advanced Buckling Analysis Method
- Section 3 Application and Structural Modelling Principles
- Section 4 Assessment Criteria
- Section 5 Strength Assessment (FEM) – Buckling Procedure
- Section 6 Ultimate Hull Girder Strength Assessments

PART 13 COMMON STRUCTURAL RULES FOR BULK CARRIERS AND OIL TANKERS**SUB-PART 1 GENERAL HULL REQUIREMENTS****CHAPTER 1 RULE GENERAL PRINCIPLES**

- Section 1 Application
- Section 2 Rule Principles
- Section 3 Verification of Compliance
- Section 4 Symbols and Definitions
- Section 5 Loading Manual and Loading Instruments

CHAPTER 2 GENERAL ARRANGEMENT DESIGN

- Section 1 General
- Section 2 Subdivision Arrangement
- Section 3 Compartment Arrangement
- Section 4 Access Arrangement

CHAPTER 3 STRUCTURAL DESIGN PRINCIPLES

- Section 1 Materials
- Section 2 Net Scantling Approach
- Section 3 Corrosion Additions
- Section 4 Corrosion Protection
- Section 5 Limit States
- Section 6 Structural Detail Principles
- Section 7 Structural Idealisation

CHAPTER 4 LOADS

- Section 1 Introduction
- Section 2 Dynamic Load Cases
- Section 3 Ship Motions and Accelerations
- Section 4 Hull Girder Loads
- Section 5 External Loads
- Section 6 Internal Loads
- Section 7 Design Load Scenarios
- Section 8 Loading Conditions

〈Appendix〉

- Appendix 1 Hold Mass Curves

CHAPTER 5 HULL GIRDER STRENGTH

- Section 1 Hull Girder Strength
- Section 2 Hull Girder Yielding Strength
- Section 3 Hull Girder Ultimate Strength

〈Appendix〉

- Appendix 1 Direct Calculation of Shear Flow
- Appendix 2 Hull Girder Ultimate Capacity

CHAPTER 6 HULL LOCAL SCANTLING

- Section 1 General
- Section 2 Load Application
- Section 3 Minimum Thicknesses
- Section 4 Plating
- Section 5 Stiffeners
- Section 6 Primary Supporting Members and Pillars

CHAPTER 7 DIRECT STRENGTH ANALYSIS

- Section 1 Strength Assessment
- Section 2 Cargo Hold Structural Strength Analysis
- Section 3 Local Structural Strength Analysis

CHAPTER 8 BUCKLING

- Section 1 General
- Section 2 Slenderness Requirements
- Section 3 Prescriptive Buckling Requirements
- Section 4 Buckling Requirements for Direct Strength Analysis
- Section 5 Buckling Capacity

〈Appendix〉

- Appendix 1 Stress Based Reference Stresses

CHAPTER 9 FATIGUE

- Section 1 General Considerations
- Section 2 Structural Details to be Assessed
- Section 3 Fatigue Evaluation
- Section 4 Simplified Stress Analysis
- Section 5 Finite Element Stress Analysis
- Section 6 Detail Design Standard

CHAPTER 10 OTHER STRUCTURES

- Section 1 Fore Part
- Section 2 Machinery Space
- Section 3 Aft Part
- Section 4 Tanks Subject to Sloshing

CHAPTER 11 SUPERSTRUCTURE, DECKHOUSES AND HULL OUTFITTING

- Section 1 Superstructures, Deckhouses and Companionways
- Section 2 Bulwark and Guard Rails
- Section 3 Equipment
- Section 4 Supporting Structure for Deck Equipment and Fittings
- Section 5 Small Hatchways

CHAPTER 12 CONSTRUCTION

- Section 1 Construction and Fabrication

Section 2 Fabrication by Welding

Section 3 Design of Weld Joints

CHAPTER 13 SHIP IN OPERATION – RENEWAL CRITERIA

Section 1 Principles and Survey Requirements

Section 2 Acceptance Criteria

SUB-PART 2 SHIP TYPES

CHAPTER 1 BULK CARRIERS

Section 1 General Arrangement Design

Section 2 Structural Design Principles

Section 3 Hull Local Scantlings

Section 4 Hull Local Scantlings for Bulk Carriers $L < 150$ m

Section 5 Cargo Hatch Covers

Section 6 Additional Class Notation Grab

CHAPTER 2 OIL TANKERS

Section 1 General Arrangement Design

Section 2 Structural Design Principles

Section 3 Hull Local Scantling

Section 4 Hull Outfitting

PART 14 STRUCTURAL RULES FOR CONTAINER SHIPS

CHAPTER 1 General Principles

Section 1 Application

Section 2 Rule Principles

Section 3 Verification of Compliance

Section 4 Symbols and Definitions

Section 5 Loading Manual and Loading Instrument

CHAPTER 2 General Arrangement

Section 1 Application

Section 2 Subdivision Arrangement

Section 3 Compartment Arrangement

Section 4 Access Arrangement

CHAPTER 3 Structural Design Principles

Section 1 Materials

Section 2 Net Scantling Approach

Section 3 Corrosion Additions

Section 4 Corrosion Protection

Section 5 Limit States

Section 6 Structural Detail Principles

Section 7 Structural Idealisation

CHAPTER 4 Loads

- Section 1 Introduction
- Section 2 Dynamic Load Cases
- Section 3 Ship Motions and Accelerations
- Section 4 Hull Girder Loads
- Section 5 External Loads
- Section 6 Internal Loads
- Section 7 Design Load Scenarios
- Section 8 Loading Conditions

CHAPTER 5 Hull Girder Strength

- Section 1 Hull Girder Yielding Strength
- Section 2 Hull Girder Ultimate Strength

〈Appendix〉

- Appendix 1 Direct Calculation of Shear Flow
- Appendix 2 Hull Girder Ultimate Capacity
- Appendix 3 Definition of Hull Girder Torsional Properties

CHAPTER 6 Hull Local Scantling

- Section 1 General
- Section 2 Load Application
- Section 3 Minimum Thicknesses
- Section 4 Plating
- Section 5 Stiffeners
- Section 6 Primary Supporting Members and Pillars

CHAPTER 7 Direct Strength Analysis

- Section 1 Strength Assessment
- Section 2 Cargo Hold Structural Strength Analysis
- Section 3 Local Structural Strength Analysis

CHAPTER 8 Buckling

- Section 1 General
- Section 2 Prescriptive Buckling Requirements
- Section 3 Buckling Requirements for Direct Strength Analysis
- Section 4 Buckling Capacity
- Section 5 Stress Based Reference Stress

CHAPTER 9 Fatigue

- Section 1 General Considerations
- Section 2 Structural Details to be Assessed
- Section 3 Fatigue Evaluation
- Section 4 Simplified Stress Analysis
- Section 5 Finite Element Stress Analysis
- Section 6 Detail Design Standard

CHAPTER 10 Other Structures

- Section 1 Fore Part
- Section 2 Machinery Space
- Section 3 Aft Part
- Section 4 Tanks Subject to Sloshing

CHAPTER 11 Superstructure, Deckhouses and Hull Outfitting

- Section 1 Superstructures, Deckhouses and Companionways
- Section 2 Bulwark and Guard Rails
- Section 3 Equipment
- Section 4 Supporting Structure for Deck Equipment and Fittings
- Section 5 Hatchways

CHAPTER 12 Construction

- Section 1 Construction and Fabrication
- Section 2 Fabrication by Welding
- Section 3 Design of Weld Joints
- Section 4 Use of Extremely Thick Steel

CHAPTER 13 Ship in Operation – Renewal Criteria

- Section 1 Principles and Survey Requirements
- Section 2 Acceptance Criteria

CHAPTER 14 Lashing Equipment

- Section 1 Lashing Equipment

PART 15 STRUCTURAL RULES FOR MEMBRANE TYPE LIQUEFIED NATURAL GAS CARRIERS

CHAPTER 1 RULE GENERAL PRINCIPLES

- Section 1 Application
- Section 2 Rule Principles
- Section 3 Verification of Compliance
- Section 4 Symbols and Definitions
- Section 5 Loading Manual and Loading Instruments

CHAPTER 2 GENERAL ARRANGEMENT DESIGN

- Section 1 General
- Section 2 Subdivision Arrangement
- Section 3 Compartment Arrangement
- Section 4 Access Arrangement

CHAPTER 3 STRUCTURAL DESIGN PRINCIPLES

- Section 1 Materials
- Section 2 Net Scantling Approach
- Section 3 Corrosion Additions
- Section 4 Corrosion Protection

- Section 5 Limit States
- Section 6 Structural Detail Principles
- Section 7 Structural Idealisation

CHAPTER 4 LOADS

- Section 1 Introduction
- Section 2 Dynamic Load Cases
- Section 3 Ship Motions and Accelerations
- Section 4 Hull Girder Loads
- Section 5 External Loads
- Section 6 Internal Loads
- Section 7 Design Load Scenarios

CHAPTER 5 HULL GIRDER STRENGTH

- Section 1 Hull Girder Yielding Strength

<Appendix>

- Appendix 1 Direct Calculation of Shear Flow

CHAPTER 6 HULL LOCAL SCANTLING

- Section 1 General
- Section 2 Load Application
- Section 3 Minimum Thicknesses
- Section 4 Plating
- Section 5 Stiffeners
- Section 6 Primary Supporting Members and Pillars

CHAPTER 7 DIRECT STRENGTH ANALYSIS

- Section 1 Strength Assessment
- Section 2 Cargo Hold Structural Strength Analysis
- Section 3 Local Structural Strength Analysis

CHAPTER 8 BUCKLING

- Section 1 General
- Section 2 Slenderness Requirements
- Section 3 Prescriptive Buckling Requirements
- Section 4 Buckling Requirements for Direct Strength Analysis
- Section 5 Buckling Capacity

<Appendix>

- Appendix 1 Stress Based Reference Stresses

CHAPTER 9 FATIGUE

- Section 1 General Considerations
- Section 2 Structural Details to be Assessed
- Section 3 Fatigue Evaluation
- Section 4 Simplified Stress Analysis

Section 5 Finite Element Stress Analysis

Section 6 Detail Design Standard

CHAPTER 10 OTHER STRUCTURES

Section 1 Fore Part

Section 2 Machinery Space

Section 3 Aft Part

CHAPTER 11 SUPERSTRUCTURE, DECKHOUSES AND HULL OUTFITTING

Section 1 Superstructures, Deckhouses and Companionways

Section 2 Bulwark and Guard Rails

Section 3 Equipment

Section 4 Supporting Structure for Deck Equipment and Fittings

CHAPTER 12 CONSTRUCTION

Section 1 Construction and Fabrication

Section 2 Fabrication by Welding

Section 3 Design of Weld Joints

CHAPTER 13 SHIP IN OPERATION – RENEWAL CRITERIA

Section 1 Principles and Survey Requirements

Section 2 Acceptance Criteria

3.2 Contents of Guidance Relating to the Rules for the Classification of Steel Ships

PART 1 CLASSIFICATION AND SURVEYS

CHAPTER 1 CLASSIFICATION

- Section 2 Character of Classification
- Section 3 Classification Survey during Construction
- Section 4 Classification Survey after Construction
- Section 8 Competence, Duties of Surveyors and Responsibility and Scope of Classification

CHAPTER 2 PERIODICAL AND OTHER SURVEYS

- Section 2 Annual Survey
- Section 3 Intermediate Survey
- Section 4 Special Survey(Hull, Equipment and Fire-extinguishing Appliances)
- Section 5-1 Special Survey(Machinery, Electrical Installations and Additional Installations)
- Section 6 Docking Survey
- Section 7 Surveys of Propeller Shaft and Stern Tube Shaft, Etc.
- Section 8 Boiler Survey
- Section 9 Continuous Survey of Machinery
- Section 10 Occasional Survey
- Section 19 Special Requirements for Ships Subject to Korean Ship Safety Act or Fishing Vessels Act

CHAPTER 3 HULL SURVEYS OF SHIPS SUBJECT TO THE ENHANCED SURVEY PROGRAMME

- Section 2 Bulk Carriers
- Section 3 Oil Tankers

〈ANNEX〉

- Annex 1-1 Character of Classification
- Annex 1-2 Void
- Annex 1-3 Example of the Survey Programme and the Survey Planning Questionnaire
- Annex 1-4 Owners Inspection Report
- Annex 1-5 Thickness Measurement Method for Hull Structural Members
- Annex 1-6 Areas of Close-up Survey, etc.
- Annex 1-7 Continuous Machinery Survey Procedure(CMS)
- Annex 1-8 Planned Maintenance System Procedure(PMS)
- Annex 1-9 Guidance for Survey of Waterjet Propulsion Systems and Azimuth or Rotatable Thruster
- Annex 1-10 Loading Instrument on Stability
- Annex 1-11 Void
- Annex 1-12 Hull Survey for Classification Survey during Construction
- Annex 1-13 Owner's Hull Inspection and Maintenance Program
- Annex 1-14 Examples of Typical Bow, Inner, Side Shell and Stern Doors
- Annex 1-15 Void
- Annex 1-16 Procedures for Testing Tanks and Tight Boundaries
- Annex 1-17 Laid-up and recommissioning of ships
- Annex 1-18 In case of promptly and thoroughly repaired, Areas to be considered

PART 2 MATERIALS AND WELDING

CHAPTER 1 MATERIALS

- Section 1 General
- Section 2 Test Specimens and Testing Procedures
- Section 3 Rolled Steels
- Section 4 Steel Tubes and Pipes
- Section 5 Castings
- Section 6 Steel Forgings
- Section 7 Copper and Copper Alloys
- Section 8 Aluminium Alloys

CHAPTER 2 WELDING

- Section 1 General
- Section 3 Welding Works and Inspection
- Section 4 Welding Procedure Qualification Tests(WPQT)
- Section 5 Welders and Welder Performance Qualification Scheme
- Section 6 Welding Consumables

〈ANNEX〉

- Annex 2-1 Guidance for Seamless Forged Steel Drums
- Annex 2-2 Guidance for Non-destructive examination of Marine Steel Castings
- Annex 2-3 Guidance for Surface Inspection of Cast Steel Crankshafts
- Annex 2-4 Guidance for Repairs by welding for Cast steel Crank Throws
- Annex 2-5 Guidance for Non-destructive Examination of Hull and Machinery Steel Forgings
- Annex 2-6 Guidance for Liquid Penetrant Inspection and Repair of Defects of Copper Alloy Propeller Castings
- Annex 2-7 Guidance for Non-destructive testing of Ship Hull Steel Welds
- Annex 2-8 Reinforced plastic materials
- Annex 2-9 Offshore Mooring Chain
- Annex 2-10 Hull Structural Steels with Improved Fatigue Properties
- Annex 2-11 High Manganese Austenitic steels
- Annex 2-12 Guidance for advanced non-destructive testing of materials and welds

PART 3 HULL STRUCTURES

CHAPTER 1 GENERAL

- Section 1 Definitions
- Section 2 General
- Section 4 Materials
- Section 5 Welding
- Section 6 Scantlings
- Section 8 Corrosion Protection Coating

CHAPTER 2 STEMS AND STERN FRAMES

- Section 1 Stems
- Section 2 Stern Frames

CHAPTER 3 LONGITUDINAL STRENGTH

- Section 1 General
- Section 2 Bending Strength
- Section 3 Shear Strength
- Section 4 Buckling Strength

CHAPTER 4 PLATE KEELS AND SHELL PLATINGS

- Section 1 General
- Section 3 Shell Plating below Strength Deck
- Section 4 Special Requirements for Shell Plating
- Section 6 Compensation at end of Superstructure
- Section 7 Local Compensation of Shell Plating

CHAPTER 5 DECKS

- Section 1 General
- Section 2 Effective Sectional Area of Strength Deck
- Section 3 Deck Plating

CHAPTER 7 DOUBLE BOTTOMS

- Section 1 General
- Section 2 Centre Girders and Side Girders
- Section 3 Solid Floors
- Section 4 Bottom Longitudinals
- Section 5 Inner Bottom Plating, Margin Plates and Bottom Shell Plating
- Section 8 Construction of Strengthened Bottom Forward

CHAPTER 8 FRAMES

- Section 1 General
- Section 3 Hold Frames
- Section 5 Tween Deck Frames

CHAPTER 9 WEB FRAMES AND SIDE STRINGERS

- Section 1 General
- Section 4 Side Transverse
- Section 5 Cantilever Beams

CHAPTER 10 BEAMS

- Section 1 General
- Section 2 Deck Load
- Section 3 Longitudinal Beams
- Section 4 Transverse Beams

CHAPTER 11 DECK GIRDERS

- Section 1 General

CHAPTER 12 PILLARS

- Section 1 General

Section 2 Scantling of Pillars

CHAPTER 13 ARRANGEMENTS TO RESIST PANTING

Section 1 General

Section 2 Arrangements to Resist Panting forward the Collision Bulkhead

Section 4 Arrangements to Resist Panting between Both Peaks

CHAPTER 14 WATERTIGHT BULKHEAD

Section 2 Arrangements of Watertight Bulkheads

Section 3 Construction of Watertight Bulkhead

Section 4 Watertight Door

CHAPTER 15 DEEP TANKS

Section 1 General

Section 2 Bulkheads of Deep Tank

CHAPTER 16 SUPERSTRUCTURES

Section 1 General

Section 3 Access Opening in Superstructure End Bulkheads

CHAPTER 17 DECKHOUSES

Section 1 General

CHAPTER 18 MACHINERY SPACES AND ENGINE CASING

Section 2 Main Engine Foundation

Section 3 Construction of Boiler Rooms

CHAPTER 19 TUNNELS AND TUNNEL RECESSES

Section 1 General

<ANNEX>

Annex 3-1 Guidance for Survey and Composition of Loading Manuals

Annex 3-2 Guidance for the Direct Strength Assessment

Annex 3-3 Guidance for the Fatigue Strength Assessment of Ship Structures

Annex 3-4 Guidance for the Hull Construction Monitoring Procedure

Annex 3-5 Guidance for structural members for ships intended to carry out the steel coils

PART 4 HULL EQUIPMENT

CHAPTER 1 RUDDERS

Section 1 General

Section 4 Rudder Strength Calculation

Section 5 Rudder Stocks

Section 6 Rudder Plates, Rudder Frames and Rudder Main Pieces

Section 7 Couplings between Rudder Stocks and Main Pieces

Section 8 Pintles

Section 9 Bearings of Rudders Stock and Pintles

Section 10 Rudder Accessories

Section 11 Propeller Nozzles

CHAPTER 2 HATCHWAYS AND OTHER DECK OPENINGS

Section 1 General

Section 2 Design Load

Section 3 Hatch cover strength criteria

Section 5 Hatch cover details – Closing Arrangement, Securing Devices and Stoppers

Section 7 Miscellaneous Openings

CHAPTER 3 BOW DOORS, SIDE AND STERN DOORS

Section 1 Bow Doors and Inner Doors

Section 2 Side Shell Doors and Stern Doors

CHAPTER 4 BULWARKS, FREEING PORTS, SIDE SCUTTLES, RECTANGULAR WINDOWS, SKYLIGHTS, VENTILATORS AND PERMANENT GANGWAYS

Section 1 Bulwarks and Guardrails

Section 2 Freeing Ports

Section 3 Side Scuttles, Rectangular Windows and Skylights

Section 4 Ventilators

Section 5 Permanent Gangways

CHAPTER 8 EQUIPMENT NUMBER AND EQUIPMENT

Section 1 General

Section 2 Equipment Number

Section 3 Anchors

Section 4 Chains

Section 5 Steel Wire Ropes

Section 6 Fibre Ropes

Section 7 Hatch Tarpaulins

Section 9 Rectangular Windows

CHAPTER 9 STRENGTH AND SECURING OF SMALL HATCHES, FITTINGS AND EQUIPMENT ON THE FORE DECK

Section 2 Strength and Securing of Small Hatches on the Exposed Fore Deck

CHAPTER 10 SHIPBOARD EQUIPMENT, FITTINGS AND SUPPORTING HULL STRUCTURES ASSOCIATED WITH TOWING AND MOORING

Section 1 Definitions and Scope of Application

Section 2 Towing and Mooring

CHAPTER 11 ACCESS TO AND WITHIN SPACES IN, AND FORWARD OF, THE CARGO AREA OF OIL TANKERS AND BULK CARRIERS

Section 1 General

Section 2 Technical Provisions for Means of Access for Inspections

<ANNEX>

Annex 4-1 Means of Access for Ballast and Cargo Tanks of Oil Tankers

- Annex 4-2 Means of Access for Bulk Carriers
- Annex 4-3 Anchoring in Deep and Unsheltered Waters
- Annex 4-4 Direct force calculation for anchoring equipment

PART 5 MACHINERY INSTALLATIONS

CHAPTER 1 GENERAL

- Section 1 General
- Section 2 Plans and Documents
- Section 3 Tests and Inspections
- Section 4 Spare Parts and Tools

CHAPTER 2 MAIN AND AUXILIARY ENGINES

- Section 1 General
- Section 2 Reciprocating Internal Combustion Engines
- Section 3 Steam Turbines

CHAPTER 3 PROPULSION SHAFTING AND POWER TRANSMISSION SYSTEMS

- Section 1 General
- Section 2 Shafting
- Section 3 Propellers
- Section 4 Power Transmission Systems
- Section 5 Water-jet propulsion systems
- Section 6 Azimuth thrusters

CHAPTER 4 TORSIONAL VIBRATION OF SHAFTING

- Section 2 Allowable Limit of Vibration Stresses

CHAPTER 5 BOILERS AND PRESSURE VESSELS

- Section 1 Boilers
- Section 2 Thermal Oil Heaters
- Section 3 Pressure Vessels
- Section 4 Welding for Boilers and Pressure Vessels

CHAPTER 6 AUXILIARIES AND PIPING ARRANGEMENT

- Section 1 General
- Section 2 Air Pipes, Overflow Pipes and Sounding Devices
- Section 3 Sea Inlet and Overboard Discharge
- Section 4 Bilge and Ballast System
- Section 5 Feed Water and Condensate System for Boiler
- Section 6 Steam and Exhaust Gas Piping
- Section 7 Cooling Water System
- Section 8 Lubricating Oil System
- Section 9 Fuel Oil System
- Section 10 Thermal Oil System
- Section 11 Compressed Air System
- Section 12 Refrigerating Machinery

- Section 13 Hydraulic System
- Section 14 Tests and Inspections

CHAPTER 7 STEERING GEARS

- Section 1 General
- Section 2 Performance and Arrangement
- Section 3 Controls
- Section 4 Materials, Constructions and Strength
- Section 5 Testing
- Section 6 Additional Requirements Concerning Tankers of 10,000 Gross Tonnage and Upwards and Other Ships of 70,000 Gross Tonnage and Upwards

CHAPTER 8 WINDLASSES AND MOORING WINCHES

- Section 1 General
- Section 2 Windlasses

〈ANNEX〉

- Annex 5-1 Requirements for Performance and Arrangement of Non-traditional Steering Systems
- Annex 5-2 Guidance for Calculation of Crankshaft Stress (1)
- Annex 5-3 Guidance for Calculation of Crankshaft Stress (2)
- Annex 5-4 Strength Calculation for Gears of Power Transmission Systems
- Annex 5-5 Requirements of Equipment for Gas welding
- Annex 5-6 Plastic Pipes
- Annex 5-7 Reciprocating Internal Combustion Engines Fuelled Natural Gas
- Annex 5-8 Guidance for the Additional Requirements on Electronically-Controlled Diesel Engines
- Annex 5-9 Flexible Pipes
- Annex 5-10 Redundant propulsion and steering system
- Annex 5-11 Documents for the approval of diesel engines
- Annex 5-12 Shaft Alignment
- Annex 5-12-1 Enhanced Shaft Alignment
- Annex 5-13 Fuel oil Treatment System

PART 6 ELECTRICAL EQUIPMENT AND CONTROL SYSTEMS

CHAPTER 1 ELECTRICAL EQUIPMENT

- Section 1 General
- Section 2 System Design
- Section 3 Rotating Machinery
- Section 4 Switchboards, Section Boards and Distribution Boards
- Section 5 Cables
- Section 6 Transformers for Power and Lighting
- Section 7 Control-gears for Motors and Magnetic Brakes
- Section 8 Fuses, Circuit-breakers and Electromagnetic Contactors
- Section 9 Explosion-protected Electrical Equipment
- Section 10 Lighting Fittings, Heating Appliances, Wiring Accessories and Miscellaneous Equipment

- Section 11 Internal Communications
- Section 12 Semi-Conductor Converters
- Section 13 Accumulator Batteries
- Section 15 High Voltage Electrical Installations
- Section 16 Electric Propulsion Unit
- Section 18 Spare Parts, Tools and Instruments

CHAPTER 2 CONTROL SYSTEMS

- Section 1 General
- Section 2 System and Control
- Section 3 Tests

PART 7 SHIPS OF SPECIAL SERVICE

CHAPTER 1 OIL TANKERS

- Section 1 General
- Section 2 Hatchways, Gangways and Freeing Arrangement
- Section 3 Longitudinal Frames and Beams in Cargo Oil Spaces
- Section 4 Girders, Transverses and Cross Ties in Cargo Oil Spaces
- Section 5 Bulkheads in Cargo Oil Spaces
- Section 6 Relative Deformation of Wing Tanks
- Section 10 Piping Systems and Venting Systems for Oil Tankers
- Section 11 Electrical Equipment of Oil Tankers

CHAPTER 2 ORE CARRIERS

- Section 1 General
- Section 3 Wing Tanks or Void Spaces
- Section 5 Relative deformation of wing tanks
- Section 7 Ore/oil carriers

CHAPTER 3 BULK CARRIERS

- Section 1 General
- Section 3 Double Bottoms
- Section 4 Hopper Tanks
- Section 5 Topside Tanks
- Section 6 Transverse Bulkhead and Stools
- Section 7 Hold Frame
- Section 8 Decks and Shell Platings
- Section 9 <Void>
- Section 11 Evaluation of Allowable Hold Loading for Bulk Carriers Considering Hold Flooding
- Section 14 Water Level Detection & Alarm and Drainage & Pumping Systems for Bulk Carriers and Single Hold Cargo Ships
- Section 15 Supplementary Provisions for Carriage of Liquid in Holds
- Section 16 Electrical Equipment in Coal Carriers
- Section 17 Renewal Criteria for Side Shell Frames and Brackets in Single Side Skin Bulk Carriers and Single Side Skin OBO Carriers

CHAPTER 4 CONTAINER CARRIERS

- Section 1 General
- Section 2 Longitudinal Strength
- Section 3 Double Bottom Construction
- Section 4 Double Side Construction
- Section 6 Deck Construction
- Section 9 Strength at Large Flare Location
- Section 10 Freight Container Securing Arrangement

CHAPTER 5 SHIPS CARRYING LIQUEFIED GASES IN BULK (Separate Publication)

- Section 1 General
- Section 2 Ship Survival Capability and Location of Cargo Tanks
- Section 3 Ship Arrangements
- Section 4 Cargo Containment
- Section 5 Process Pressure Vessels and Liquid, Vapour and Pressure Piping Systems
- Section 6 Materials of Construction and Quality Control
- Section 7 Cargo Pressure/Temperature Control
- Section 8 Vent Systems for Cargo Containment
- Section 9 Cargo Containment System Atmosphere Control
- Section 10 Electrical Installations
- Section 11 Fire Protection and Fire Extinction
- Section 12 Mechanical Ventilation in the Cargo Area
- Section 13 Instrumentation and Automation Systems
- Section 15 Filling Limits for Cargo Tanks
- Section 16 Use of Cargo as Fuel
- Section 17 Special Requirements
- Section 18 Operating Requirements
- Section 19 Summary of Minimum Requirements

CHAPTER 6 SHIPS CARRYING DANGEROUS CHEMICALS IN BULK (Separate Publication)

- Section 1 General
- Section 2 Ship Survival Capability and Location of Cargo Tanks
- Section 3 Ship Arrangements
- Section 5 Cargo Transfer
- Section 7 Cargo Temperature Control
- Section 8 Cargo Tank Venting and Gas-freeing Arrangements
- Section 9 Environmental Control
- Section 10 Electrical Installations
- Section 11 Fire Protection and Fire Extinction
- Section 12 Mechanical Ventilation in the Cargo Area
- Section 13 Instrumentation
- Section 14 Personnel Protection
- Section 15 Special Requirements
- Section 16 Operational Requirements

<Annex>

- Annex 7A-1 Requirements for Ships not having the International Certificate of Fitness for the Carriage of Liquefied Gases in Bulk
- Annex 7A-2 Guidelines for the Evaluation of the Adequacy of Type C Tank Vent Systems
- Annex 7A-3 LNG Bunkering Systems
- Annex 7A-4 High manganese austenitic steel for cryogenic service
- Annex 7A-5 Use of LPG Cargo as Fuel
- Annex 7A-6 Non-Metallic Materials
- Annex 7A-7 Standard for the Use of Limit State Methodologies in the Design of Cargo Containment Systems of Novel Configuration
- Annex 7A-8 Guidelines for Safety Containment of Cargo Containment Facilities
- Annex 7B-1 Table of Summary of Minimum Requirements
- Annex 7B-2 List of Products to which the Code does not apply
- Annex 7B-3 Index of Products Carried in Bulk
- Annex 7B-4 Criteria for assigning carriage requirements for products subject to the IBC Code

CHAPTER 7 CAR FERRIES AND ROLL-ON/ROLL-OFF SHIPS

- Section 3 Deck Structure

CHAPTER 10 DOUBLE HULL TANKER

- Section 1 General
- Section 2 Bulkhead Plating
- Section 3 Longitudinals and Stiffeners
- Section 4 Girders
- Section 5 Structural Details
- Section 6 Special Requirements for Corrosion
- Section 8 Special Requirements for Tankers with Mid-deck
- Section 9 Special Requirements for Hatchways and Freeing Arrangements
- Section 10 Welding

<ANNEX>

- Annex 7-1 Additional Requirements for Oil Tankers Using Oil as a Fuel for Boilers
- Annex 7-2 Guidance for the Container Securing Arrangements
- Annex 7-3 Guidance for Car Ferries
- Annex 7-4 Guidance for Calculating the Maximum Allowable and Minimum Required Mass of Cargo and Double Bottom Contents with Bulk Carriers
- Annex 7-5 Additional Requirements for Existing Bulk Carriers
- Annex 7-6 Water Level Detection & Alarm and Drainage & Pumping Arrangements for Bulk Carriers and Single Hold Cargo Ships
- Annex 7-6-1 Water Level Detectors on Multiple Hold Cargo Ships other than Bulk Carriers and Tankers
- Annex 7-7 Unified Interpretation of Convention
- Annex 7-8 Instruction for Use of Extremely Thick Steel Plates in Container Ships
- Annex 7-9 Guidance for the Longitudinal Strength of Container Ships
- Annex 7-10 Guidance for the Direct Strength Assessment for Ore Carriers

Annex 7-11 Guidance on Providing Safe Working Conditions for Securing of Container on Deck
Annex 7-12 Liquefaction of Ore Bulk Cargo

PART 8 FIRE PROTECTION AND FIRE EXTINCTION

CHAPTER 1 GENERAL

Section 1 General

CHAPTER 2 PROBABILITY OF IGNITION

Section 1 Arrangements for Oil Fuel, Lubrication Oil and Other Flammable Oils
Section 2 Arrangements for Gaseous Fuel for Domestic Purpose
Section 3 Miscellaneous Items of Ignition Sources And Ignitability
Section 4 Cargo Areas of Tankers

CHAPTER 3 FIRE GROWTH POTENTIAL

Section 1 Control of Air Supply And Flammable Liquid to The Spaces
Section 2 Fire Protection Materials

CHAPTER 4 SMOKE GENERATION POTENTIAL AND TOXICITY

Section 1 Paints, Varnishes And Other Finishes
Section 2 Primary Deck Coverings

CHAPTER 5 DETECTION AND ALARM

Section 1 General
Section 2 Protection of Machinery Spaces
Section 3 Protection of Accommodation And Service Spaces And Control Stations
Section 5 Manually Operated Call Points
Section 8 Protection of cabin balconies on passenger ships

CHAPTER 6 CONTROL OF SMOKE SPEED

Section 1 Protection of Control Stations Outside Machinery Space
Section 3 Draft Stops

CHAPTER 7 CONTAINMENT OF FIRE

Section 1 Thermal And Structural Boundaries
Section 2 Penetration in Fire-resisting Divisions And Prevention of Heat Transmission
Section 3 Protection of Openings in Fire-resisting Divisions
Section 5 Protection of Cargo Space Boundaries
Section 6 Ventilation Systems

CHAPTER 8 FIRE FIGHTING

Section 1 Water Supply System
Section 2 Portable Fire Extinguishers
Section 3 Fixed Fire-extinguishing Systems
Section 4 Fire Extinguishing Arrangements In Machinery Spaces
Section 5 Fire-extinguishing Arrangements In Control Stations, Accommodation And Service Spaces
Section 6 Fire-extinguishing Arrangements In Cargo Spaces

- Section 7 Cargo Tank Protection
- Section 8 Protection of Cargo Pump Room
- Section 9 Fire-fighter's Outfit

CHAPTER 9 STRUCTURAL INTEGRITY

- Section 1 Material
- Section 2 Structure of aluminium alloy
- Section 3 Machinery Spaces of Category A
- Section 4 Materials of Overboard Fittings
- Section 5 Protection of Cargo Tank Structure Against Pressure Or Vacuum In Tankers

CHAPTER 10 ESCAPE

- Section 2 Means of escape

CHAPTER 11 HELICOPTER FACILITIES

- Section 1 Application
- Section 4 Fire-fighting Appliances

CHAPTER 12 CARRIAGE OF DANGEROUS GOODS

- Section 1 General Requirements
- Section 2 Special Requirements
- Section 3 Document of Compliance

CHAPTER 13 PROTECTION OF VEHICLE, SPECIAL CATEGORY, OPEN AND CLOSED RO-RO SPACES, AND WEATHER DECKS INTENDED FOR THE CARRIAGE OF VEHICLES

- Section 1 General Requirements
- Section 2 Precaution against ignition of flammable vapours in closed vehicle spaces closed ro-ro spaces and special category spaces
- Section 5 Fire-extinction

⟨ANNEX⟩

- Annex 8-1 Fire Protection Materials
- Annex 8-2 Penetrations through Divisions
- Annex 8-3 Alleviation Requirements for Ships which are not engaged in international voyage and Ships of less than 500 gross tonnage
- Annex 8-4 Alleviation Requirements for Fishing Vessels
- Annex 8-5 Inert Gas Systems
- Annex 8-6 Other Operation Requirements, etc.
- Annex 8-7 Safe Return to Port System on Passenger Ships
- Annex 8-8 Qualitative Failure Analysis for Propulsion and Steering on Passenger Ships - ⟨Void⟩
- Annex 8-9 Special Requirements of Fire Protection and Fire Extinction for Cargo Ships

PART 9 ADDITIONAL INSTALLATIONS

CHAPTER 1 CARGO REFRIGERATING INSTALLATIONS

- Section 1 General
- Section 2 Surveys

- Section 3 Refrigerating Machinery
- Section 4 Special Requirements for Refrigerating Machinery Using Ammonia as Refrigerant
- Annex 9-1 Spare Parts (for Reference)

CHAPTER 2 CARGO HANDLING APPLIANCES

- Section 1 General
- Section 2 Surveys
- Section 3 Derrick Systems
- Section 4 Cranes
- Section 5 Cargo Fittings
- Section 6 Loose Gear
- Section 7 Machinery, Electrical Installations and Control Engineering Systems
- Section 8 Cargo Lifts and Cargo Ramps
- Annex 9-2 Personnel Lifting Appliance
- Annex 9-3 Offshore Cranes

CHAPTER 3 AUTOMATIC AND REMOTE CONTROL SYSTEMS

- Section 2 Surveys of Automatic and Remote Control Systems
- Section 3 Centralized Monitoring and Control Systems for Main Propulsion and Essential Auxiliary Machinery
- Section 5 Specific Automatic Equipment

CHAPTER 4 DYNAMIC POSITIONING SYSTEMS(DP SYSTEMS)

- Section 2 Requirements of DP Systems

CHAPTER 5 NAVIGATION BRIDGE SYSTEMS

- Section 2 Surveys of Navigation Bridge Systems
- Section 5 Accident Prevention Systems
- Section 6 Bridge Work Assist Systems

CHAPTER 7 DIVING SYSTEMS

- Section 1 General
- Section 2 Classification Survey
- Section 3 Inspection and Testing
- Section 5 PVHO
- Section 6 Deck Decompression Chambers and divers transfer system
- Section 7 Life Support System
- Section 10 Launch and Recovery System
- Section 11 Hyperbaric Rescue Unit

CHAPTER 9 CARGO VAPOUR EMISSION CONTROL SYSTEMS

- Section 3 Requirements for VEC2 Notation

CHAPTER 10 BALLAST WATER MANAGEMENT

- Section 3 Ballast Water Management Systems
- Section 4 Installation of BWMS on-board ships
- Annex 9-4 BWMS Technologies categorization

PART 10 HULL STRUCTURE AND EQUIPMENT OF SMALL STEEL SHIPS

CHAPTER 1 GENERAL

- Section 1 Definitions
- Section 2 General
- Section 3 Materials, Welding and Construction

CHAPTER 2 STEMS AND STERN FRAMES

- Section 1 Stems
- Section 2 Stern Frames

CHAPTER 3 LONGITUDINAL STRENGTH

- Section 1 General
- Section 2 Bending Strength

CHAPTER 4 PLATE KEELS AND SHELL PLATINGS

- Section 3 Shell Plating for Midship Part of Ship
- Section 4 Shell Plating for End Parts
- Section 5 Side Plating in way of Superstructure
- Section 6 Local Compensation of Shell Plating

CHAPTER 5 DECKS

- Section 1 General
- Section 2 Effective Sectional Area of Strength Deck

CHAPTER 7 DOUBLE BOTTOMS

- Section 1 General
- Section 5 Bottom Longitudinals
- Section 6 Inner Bottom Plating and Margin Plates
- Section 9 Construction of Strengthened Bottom Forward

CHAPTER 8 FRAMES

- Section 1 General
- Section 3 Transverse Hold Frames
- Section 5 Tween Deck Frames

CHAPTER 9 CANTILEVER BEAM CONSTRUCTION

- Section 3 Connection of Cantilever Beams to Web Frames

CHAPTER 10 BEAMS

- Section 1 General
- Section 2 Deck Load
- Section 3 Longitudinal Beams
- Section 4 Transverse Beams

CHAPTER 11 DECK GIRDERS

- Section 1 General

Section 2 Longitudinal Deck Girders

CHAPTER 12 PILLARS

Section 1 General

Section 2 Scantling of Pillars

CHAPTER 13 ARRANGEMENTS TO RESIST PANTING

Section 1 General

Section 2 Arrangements to resist Panting Forward the Collision Bulkhead

CHAPTER 14 WATERTIGHT BULKHEADS

Section 1 Arrangement

Section 2 Construction

Section 3 Watertight Doors

CHAPTER 15 DEEP TANKS

Section 1 General

Section 2 Bulkheads of Deep Tanks

CHAPTER 16 SUPERSTRUCTURES AND DECKHOUSES

Section 1 General

Section 3 Access Openings in Superstructure End Bulkheads

CHAPTER 17 MACHINERY SPACES AND ENGINE CASINGS

Section 1 General

Section 2 Main Engine Foundations

CHAPTER 19 HATCHWAYS AND OTHER DECK OPENINGS

Section 1 General

CHAPTER 21 BULWARKS, FREEING PORTS, SIDE SCUTTLES, VENTILATORS AND PERMANENT GANGWAYS

Section 2 Freeing Ports

Section 3 Side Scuttles

CHAPTER 22 EQUIPMENT NUMBER AND EQUIPMENT

Section 1 General

CHAPTER 23 OIL TANKERS

Section 1 General

Section 2 Hatchways, Gangways and Freeing Arrangements

Section 6 Bulkheads in Cargo Oil Space

CHAPTER 24 DOUBLE HULL TANKERS

Section 1 General

Section 2 Bulkhead Plating

Section 10 Special Requirements for Hatchways and Permanent Gangways

PART 13 COMMON STRUCTURAL RULES FOR BULK CARRIERS AND OIL TANKERS

SUB-PART 1 GENERAL HULL REQUIREMENTS

CHAPTER 1 RULE GENERAL PRINCIPLES

Section 2 Rule Principles

CHAPTER 3 STRUCTURAL DESIGN PRINCIPLES

Section 1 Materials

CHAPTER 4 LOADS

Section 6 Internal Loads

CHAPTER 10 OTHER STRUCTURES

Section 4 Tanks Subject to Sloshing

<ANNEX>

Annex 13-1 Wave Load Analysis Procedure

PART 14 STRUCTURAL RULES FOR CONTAINER SHIPS

<ANNEX>

Annex 14-1 Strength assessment of flooded condition for fire-fighting

3.3 Contents of Rules for Offshore Structure

RULES FOR THE CLASSIFICATION OF MOBILE OFFSHORE UNITS

CHAPTER 1 GENERAL

- Section 1 General
- Section 2 Definitions

CHAPTER 2 CLASSIFICATION AND SURVEYS

- Section 1 General
- Section 2 Classification
- Section 3 Surveys

CHAPTER 3 HULL CONSTRUCTION AND EQUIPMENT

- Section 1 General
- Section 2 Materials
- Section 3 Welding
- Section 4 Ice Strengthening
- Section 5 Corrosion Control
- Section 6 Fire Protection, Means of Escape and Fire Detection & Extinction
- Section 7 Guardrails and Bulwarks
- Section 8 Temporary or Emergency Mooring Equipment
- Section 9 Access
- Section 10 Towing Arrangements
- Section 11 Protective Coatings of Dedicated Seawater Ballast Tanks
- Section 12 Anti-fouling Systems
- Section 13 Drainage and Sediment Control

CHAPTER 4 DESIGN CONDITION

- Section 1 Design Loads
- Section 2 Calculation of Strength
- Section 3 Analysis of Overall Strength
- Section 4 Scantlings of Structural Members
- Section 5 Helicopter Deck
- Section 6 Position Keeping Systems and Components

CHAPTER 5 TYPE OF UNITS

- Section 1 Self-elevating Units
- Section 2 Column-Stabilized Units
- Section 3 Surface Type Units

CHAPTER 6 WATERTIGHT INTEGRITY

- Section 1 Watertight Bulkheads
- Section 2 Closing Appliances

CHAPTER 7 STABILITY

- Section 1 General Requirements of Stability
- Section 2 Stability Criterion under Wind Force

CHAPTER 8 HAZARDOUS AREA

- Section 1 General
- Section 2 Extent of Hazardous Area
- Section 3 Ventilation

CHAPTER 9 FIRE PROTECTION, MEANS OF ESCAPE AND FIRE EXTINCTION

- Section 1 General
- Section 2 Fire Protection and Means of Escape
- Section 3 Fire Detection and Extinction
- Section 4 Fire Extinguishing Systems for Helicopter Facilities
- Section 5 Gas Cylinders
- Section 6 Offshore Accommodation Units

CHAPTER 10 MACHINERY INSTALLATIONS AND ELECTRICAL EQUIPMENT

- Section 1 Machinery Installations and Electrical Equipment for Units
- Section 2 Machinery Installations and Electrical Equipment for Self-propelled Units

CHAPTER 11 SPECIFIC OFFSHORE UNIT TYPES

- Section 1 Offshore Work Units
- Section 2 Offshore Accommodation Units
- Section 3 Floating Piers
- Section 4 Offshore Plant Units
- Section 5 Wind Turbine Installation Units

RULES FOR THE CLASSIFICATION OF FIXED OFFSHORE STRUCTURES

CHAPTER 1 GENERAL

- Section 1 General

CHAPTER 1 CLASSIFICATION AND SURVEYS

- Section 1 General
- Section 2 Classification
- Section 3 Surveys
- Section 4 Extension of Use and Reuse

CHAPTER 3 MATERIALS AND WELDING

- Section 1 Materials
- Section 2 Welding

CHAPTER 4 DESIGN OF STRUCTURES

- Section 1 Definition and Design Documentation
- Section 2 Environmental Condition
- Section 3 Loads
- Section 4 General Design Requirements
- Section 5 Steel Structures
- Section 6 Concrete Structure

- Section 7 Foundation
- Section 8 Installation
- Section 9 Marine Operation

CHAPTER 5 MACHINERY INSTALLATIONS

- Section 1 General
- Section 2 Engines, Boilers and Pressure Vessels
- Section 3 Auxiliaries and Piping Arrangement

CHAPTER 5 ELECTRICAL INSTALLATIONS, SAFETY FEATURES AND FIRE PROTECTION

- Section 1 Electrical Installation
- Section 2 Safety Features and Fire Protection

RULES FOR THE CLASSIFICATION OF MOBILE OFFSHORE DRILLING UNITS

CHAPTER 1 GENERAL

- Section 1 General
- Section 2 Definitions

CHAPTER 2 CLASSIFICATION AND SURVEYS

- Section 1 General
- Section 2 Classification
- Section 3 Surveys

CHAPTER 3 CONSTRUCTION, STRENGTH AND MATERIALS

- Section 1 General
- Section 2 Access
- Section 3 Design Loads
- Section 4 Calculation of Strength
- Section 5 Surface Type Units
- Section 6 Self-elevating Units
- Section 7 Column-stabilized Units
- Section 8 Towing Arrangements
- Section 9 Fatigue Analysis
- Section 10 Materials
- Section 11 Anti-fouling Systems
- Section 12 Protective Coatings of Dedicated Seawater Ballast Tanks
- Section 13 Construction Portfolio
- Section 14 Welding
- Section 15 Drainage and Sediment Control
- Section 16 Ice Strengthening
- Section 17 Corrosion Control
- Section 18 Guardrails and Bulwarks
- Section 19 Temporary or Emergency Mooring Equipment

CHAPTER 4 SUBDIVISION, STABILITY AND FREEBOARD

- Section 1 Inclining Test

- Section 2 Righting Moment and Heeling Moment Curves
- Section 3 Intact Stability Criteria
- Section 4 Subdivision and Damage Stability
- Section 5 Extent of Damage
- Section 6 Watertight Integrity
- Section 7 Freeboard

CHAPTER 5 MACHINERY INSTALLATIONS OF ALL TYPES OF UNITS

- Section 1 General
- Section 2 Machinery Installations

CHAPTER 6 ELECTRICAL INSTALLATIONS FOR ALL TYPES OF UNITS

- Section 1 General
- Section 2 Electrical Installations
- Section 3 Alarms and Internal Communication

CHAPTER 7 MACHINERY AND ELECTRICAL INSTALLATIONS IN HAZARDOUS AREAS

- Section 1 General
- Section 2 Extent of Hazardous Area
- Section 3 Ventilation
- Section 4 Emergency Shutdown for Electrical Equipment
- Section 5 Electrical Installations in Hazardous Areas
- Section 6 Machinery Installations in Hazardous Areas

CHAPTER 8 MACHINERY AND ELECTRICAL INSTALLATIONS FOR SELF-PROPELLED UNITS

- Section 1 General
- Section 2 Means of Going Astern
- Section 3 Steam Boilers and Boiler Feed Systems
- Section 4 Machinery Controls
- Section 5 Steering
- Section 6 Communication between the Navigating Bridge and the Engine Room
- Section 7 Engineers' Alarm
- Section 8 Main Source of Electrical Power

CHAPTER 9 PERIODICALLY UNATTENDED MACHINERY SPACES FOR ALL TYPES OF UNITS

- Section 1 General
- Section 2 Fire Protection and Fire Fighting
- Section 3 Protection against Flooding
- Section 4 Bridge Control of Propulsion Machinery
- Section 5 Communication and Alarm System
- Section 6 Special Provisions for Machinery, Boiler and Electrical Installations
- Section 7 Safety Systems

CHAPTER 10 FIRE PROTECTION, MEANS OF ESCAPE AND FIRE EXTINCTION

- Section 1 General
- Section 2 Fire Protection and Means of Escape
- Section 3 Fire Extinction

- Section 4 Fire Extinguishing Systems for Helicopter Facilities
- Section 5 Gas Cylinders
- Section 6 Other Operational Requirements

CHAPTER 11 LIFTING DEVICES, PERSONNEL AND PILOT TRANSFER

- Section 1 Cranes
- Section 2 Lifting and Hoisting Equipment
- Section 3 Personnel Lifts
- Section 4 Personnel and Pilot Transfer
- Section 5 Drilling Derricks

CHAPTER 12 HELICOPTER FACILITIES

- Section 1 General
- Section 2 Definitions
- Section 3 Construction
- Section 4 Arrangements
- Section 5 Visual Aids
- Section 6 Motion Sensing System
- Section 7 Exemptions

3.4 Contents of Guidance for Offshore Structures
**GUIDANCE RELATING TO THE RULES FOR THE CLASSIFICATION OF MOBILE
OFFSHORE DRILLING UNITS**

CHAPTER 1 GENERAL

Section 1 General

CHAPTER 3 CONSTRUCTION, STRENGTH AND MATERIALS

Section 2 Access

CHAPTER 7 MACHINERY AND ELECTRICAL INSTALLATIONS IN HAZARDOUS AREAS

Section 5 Electrical Installations in Hazardous

CHAPTER 11 LIFTING DEVICES, PERSONNEL AND PILOT TRANSFER

Section 5 Drilling Derricks

〈ANNEX〉

Annex 1 Drilling Systems

Annex 2 Technical Provisions of Means of Access

GUIDANCE FOR MOBILE OFFSHORE UNITS

CHAPTER 7 STABILITY

Section 1 General Requirements of Stability

GUIDANCE FOR FLOATING PRODUCTION UNITS

CHAPTER 1 GENERAL

Section 1 General

Section 2 Definition

CHAPTER 2 CLASSIFICATION AND SURVEYS

Section 1 General

Section 2 Classification

Section 3 Surveys

CHAPTER 3 DESIGN CONDITIONS

Section 1 General

Section 2 Design Principles

Section 3 Corrosion Control Means and Corrosion Margins

Section 4 Design Loads

CHAPTER 4 MATERIALS AND WELDING

Section 1 General

CHAPTER 5 HULL CONSTRUCTION AND EQUIPMENT

Section 1 General

Section 2 Stability

- Section 3 Longitudinal Strength
- Section 4 Structural Design and Analysis of the Hull
- Section 5 Design and Analysis of Other Major Hull Structural Features
- Section 6 Structural Strength for Column-stabilized and Other Type Units
- Section 7 Hull Equipment

CHAPTER 6 POSITIONING SYSTEMS

- Section 1 General
- Section 2 Mooring Analysis
- Section 3 Design of Mooring Lines, etc.
- Section 4 Mooring Equipment
- Section 5 Single Point Mooring Systems
- Section 6 Anchor Holding Power
- Section 7 Dynamic Positioning Systems

CHAPTER 7 HAZARDOUS AREA

- Section 1 General
- Section 2 Extent of Hazardous Area
- Section 3 Ventilation

CHAPTER 8 FIRE PROTECTION, MEANS OF ESCAPE AND FIRE EXTINCTION

- Section 1 General
- Section 2 Prevention of Fire and Explosion
- Section 3 Suppression of Fire
- Section 4 Means of Escape

CHAPTER 9 MACHINERY INSTALLATIONS

- Section 1 General
- Section 2 Piping Systems for Crude Oil Tanks
- Section 3 Use of Produced Gas as Fuel
- Section 4 Boilers Using Crude Oil

CHAPTER 10 ELECTRICAL EQUIPMENT AND CONTROL SYSTEMS

- Section 1 Electrical Equipment
- Section 2 Control Systems

CHAPTER 11 PRODUCTION AND PROCESS SYSTEMS

- Section 1 General
- Section 2 Design of Process Systems
- Section 3 Process System Equipment
- Section 4 Process Support Systems

CHAPTER 12 IMPORT AND EXPORT SYSTEMS

- Section 1 General
- Section 2 Design

GUIDANCE FOR FLOATING LIQUEFIED GAS STORAGE AND REGASIFICATION UNITS

CHAPTER 1 GENERAL

- Section 1 General
- Section 2 Definitions

CHAPTER 2 CLASSIFICATION AND SURVEYS

- Section 1 General
- Section 2 Classification Survey
- Section 3 Surveys

CHAPTER 3 DESIGN CONDITION

- Section 1 General
- Section 2 Design Principles
- Section 3 Corrosion Control Means and Corrosion Margins
- Section 4 Design Loads

CHAPTER 4 MATERIALS AND WELDING

- Section 1 General

CHAPTER 5 HULL CONSTRUCTION AND EQUIPMENT

- Section 1 General
- Section 2 Survival Capability and Location of Cargo Tanks
- Section 3 Longitudinal Strength
- Section 4 Structural Design and Analysis of the Hull
- Section 5 Design and Analysis of Other Major Hull Structural Features
- Section 6 Direct Strength Assessment
- Section 7 Fatigue Strength Assessment
- Section 8 Hull Arrangements
- Section 9 Cargo Containment
- Section 10 Hull Equipment

CHAPTER 6 POSITIONING SYSTEMS

- Section 1 General

CHAPTER 7 HAZARDOUS AREA

- Section 1 Hazardous Area
- Section 2 Ventilation

CHAPTER 8 FIRE PROTECTION, MEANS OF ESCAPE AND FIRE EXTINCTION

- Section 1 General
- Section 2 Suppression of Fire
- Section 3 Means of Escape

CHAPTER 9 MACHINERY INSTALLATIONS

- Section 1 General
- Section 2 Piping Systems for Cargo Tanks
- Section 3 Use of Natural Gas as Fuel

CHAPTER 10 ELECTRICAL EQUIPMENTS AND CONTROL SYSTEMS

- Section 1 Electrical Equipments
- Section 2 Control Systems

CHAPTER 11 PERSONNEL PROTECTION

CHAPTER 12 REGASIFICATION SYSTEM

- Section 1 General
- Section 2 Design of Regasification Systems
- Section 3 Regasification System Equipments

CHAPTER 13 LOADING SYSTEMS

- Section 1 General
- Section 2 Cargo Transfer Connection
- Section 3 Transfer Arms
- Section 4 Transfer Hoses
- Section 5 Safety Systems
- Section 6 Communication Systems
- Section 7 Mooring Equipment

CHAPTER 14 EXPORT SYSTEM

- Section 1 General

GUIDANCE FOR FLOATING LIQUEFIED GAS PRODUCTION UNITS

CHAPTER 1 GENERAL

- Section 1 General
- Section 2 Definitions

CHAPTER 2 CLASSIFICATION AND SURVEYS

- Section 1 General
- Section 2 Classification Survey
- Section 3 Surveys

CHAPTER 3 DESIGN CONDITION

- Section 1 General
- Section 2 Design Principles
- Section 3 Corrosion Control Means and Corrosion Margins
- Section 4 Design Loads

CHAPTER 4 MATERIALS AND WELDING

- Section 1 General

CHAPTER 5 HULL CONSTRUCTION AND EQUIPMENT

- Section 1 General
- Section 2 Survival Capability and Location of Cargo Tanks
- Section 3 Longitudinal Strength

- Section 4 Structural Design and Analysis of the Hull
- Section 5 Design and Analysis of Other Major Hull Structural Features
- Section 6 Direct Strength Assessment
- Section 7 Fatigue Strength Assessment
- Section 8 Hull Arrangements
- Section 9 Cargo Containment
- Section 10 Hull Equipment

CHAPTER 6 POSITIONING SYSTEMS

- Section 1 General

CHAPTER 7 HAZARDOUS AREA

- Section 1 Hazardous Area
- Section 2 Ventilation

CHAPTER 8 FIRE PROTECTION, MEANS OF ESCAPE AND FIRE EXTINCTION

- Section 1 General
- Section 2 Prevention of Fire and Explosion
- Section 3 Suppression of Fire
- Section 4 Means of Escape

CHAPTER 9 MACHINERY INSTALLATIONS

- Section 1 General
- Section 2 Piping Systems for Cargo Tanks
- Section 3 Use of Natural Gas as Fuel

CHAPTER 10 ELECTRICAL EQUIPMENTS AND CONTROL SYSTEMS

- Section 1 Electrical Equipments
- Section 2 Control Systems

CHAPTER 11 PERSONNEL PROTECTION

CHAPTER 12 PROCESS SYSTEMS

- Section 1 General
- Section 2 Design of Process Systems
- Section 3 Process System Equipment
- Section 4 Process Support Systems

CHAPTER 13 OFFLOADING SYSTEMS

- Section 1 General
- Section 2 Cargo Transfer Connection
- Section 3 Transfer Arms
- Section 4 Transfer Hoses
- Section 5 Safety Systems
- Section 6 Communication Systems
- Section 7 Mooring Equipment

CHAPTER 14 IMPORT SYSTEM

Section 1 General

GUIDANCE FOR OSV

CHAPTER 1 GENERAL

Section 1 General

Section 2 Definitions

CHAPTER 2 CLASSIFICATION AND SURVEYS

Section 1 General

Section 2 Classification

Section 3 Surveys

CHAPTER 3 STRUCTURES AND EQUIPMENT

Section 1 Stability

Section 2 Hull Structures

Section 3 Hull Equipment

Section 4 Machinery

Section 5 Electrical Installations

Section 6 Fire Protection and Fire Extinguishing Systems

CHAPTER 4 OFFSHORE SUPPLY VESSELS

Section 1 General

Section 2 Hull Structures

Section 3 Cargo Piping Systems

Section 4 Machinery

CHAPTER 5 ANCHOR HANDLING AND TOWING VESSELS

Section 1 General

Section 2 Stability

Section 3 Hull Structures

Section 4 Hull Equipment

Section 5 Anchor Handling/Towing Winch and Accessories

Section 6 Machinery

Section 7 Fire Protection and Fire Extinguishing Systems

CHAPTER 6 HEAVY LIFT VESSELS

Section 1 General

Section 2 Stability

Section 3 Hull Structures

Section 4 Hull Equipment

Section 5 Machinery

Section 6 Positioning System

CHAPTER 7 WIND TURBINE INSTALLATION VESSELS

- Section 1 General
- Section 2 Stability
- Section 3 Hull Structures
- Section 4 Hull Equipment
- Section 5 Machinery
- Section 6 Positioning System

CHAPTER 8 FIRE FIGHTING VESSELS

- Section 1 General
- Section 2 Stability
- Section 3 Hull Structures
- Section 4 Fire Fighting Equipment for Other vessels
- Section 5 Machinery
- Section 6 Fire Protection and Fire Extinguishing Systems
- Section 7 Positioning System

CHAPTER 9 OIL SPILL RECOVERY VESSELS

- Section 1 General
- Section 2 Definitions
- Section 3 Hull Structures
- Section 4 Hull Equipment
- Section 5 Tank Arrangement
- Section 6 Machinery and Electrical Installations in Hazardous Areas
- Section 7 Fire Protection and Fire Extinguishing Systems

CHAPTER 10 CABLE LAYING VESSEL

- Section 1 General
- Section 2 Stability
- Section 3 Hull Structures
- Section 4 Hull Equipment
- Section 5 Machinery
- Section 6 Positioning System
- Section 7 Fire Protection and Fire Fighting

CHAPTER 11 CREW TRANSFER VESSEL

- Section 1 General
- Section 2 Stability
- Section 3 Hull Structures
- Section 4 Hull Equipment
- Section 5 Safe Transfer of Personnel

(ANNEX)

- Annex 1 Ships Carrying Industrial Personnel(IP)

3.5 Contents of Other Rules

RULES FOR THE CLASSIFICATION OF STEEL BARGES

CHAPTER 1 GENERAL

- Section 1 Definitions
- Section 2 General
- Section 3 Materials, Welding and Construction

CHAPTER 2 CLASSIFICATION SURVEYS

- Section 1 General
- Section 2 Classification Survey during Construction
- Section 3 Periodical Surveys

CHAPTER 3 STEMS

- Section 1 Stems

CHAPTER 4 LONGITUDINAL STRENGTH

- Section 1 General
- Section 2 Bending Strength

CHAPTER 5 PLATE KEELS AND SHELL PLATINGS

- Section 1 General
- Section 2 Plate Keels
- Section 3 Shell Plating for Midship Part of Barge
- Section 4 Shell Plating for End Parts
- Section 5 Side Plating in way of Superstructure
- Section 6 Local Compensation of Shell Plating

CHAPTER 6 DECKS

- Section 1 General
- Section 2 Effective Sectional Area of Strength Deck
- Section 3 Deck Plating

CHAPTER 7 SINGLE BOTTOMS

- Section 1 General
- Section 2 Centre Keelsons
- Section 3 Side Keelsons
- Section 4 Floor Plates
- Section 5 Longitudinals
- Section 6 Strengthened Bottom Forward

CHAPTER 8 DOUBLE BOTTOMS

- Section 1 General
- Section 2 Centre Girders
- Section 3 Side Girders
- Section 4 Solid Floors
- Section 5 Longitudinals
- Section 6 Inner Bottom Plating and Margin Plates

- Section 7 Frame End Brackets
- Section 8 Open Floors
- Section 9 Construction of Strengthened Bottom Forward

CHAPTER 9 FRAMES

- Section 1 General
- Section 2 Frame Spacing
- Section 3 Transverse Hold Frames
- Section 4 Side Longitudinals
- Section 5 Superstructure Frames
- Section 6 Frames in Both Peaks

CHAPTER 10 BEAMS

- Section 1 General
- Section 2 Deck Load
- Section 3 Longitudinal Beams
- Section 4 Transverse Beams
- Section 5 Beams on Bulkhead Recess and Others
- Section 6 Beams on the Top of Deep Tanks
- Section 7 Deck Beams Supporting Specially Heavy Loads

CHAPTER 11 DECK GIRDERS AND HATCH END BEAMS

- Section 1 General
- Section 2 Longitudinal Deck Girders
- Section 3 Transverse Deck Girders
- Section 4 Deck Girders in Tanks
- Section 5 Hatch Side Girders
- Section 6 Hatch End Girders

CHAPTER 12 PILLARS AND TRUSSES

- Section 1 General
- Section 2 Scantling of Pillars
- Section 3 Trusses

CHAPTER 13 PEAK CONSTRUCTION

- Section 1 General
- Section 2 Arrangements of Construction Forward of the Collision Bulkhead
- Section 3 Arrangements of Construction Aft of Peak Bulkhead

CHAPTER 14 WATERTIGHT BULKHEADS

- Section 1 Arrangement
- Section 2 Construction

CHAPTER 15 DEEP TANKS

- Section 1 General
- Section 2 Bulkheads of Deep Tanks
- Section 3 Fittings of Deep Tanks

CHAPTER 16 SUPERSTRUCTURE AND DECKHOUSE

- Section 1 General
- Section 2 Construction and Scantlings
- Section 3 Access Openings in Superstructure End Bulkheads

CHAPTER 17 HATCHWAYS AND OTHER DECK OPENINGS

- Section 1 General
- Section 2 Hatchways
- Section 3 Hatch Covers
- Section 4 Companion-ways and Other Deck Openings

CHAPTER 18 BULWARKS, FREEING PORTS, VENTILATORS AND PERMANENT GANGWAYS

- Section 1 General
- Section 2 Bulwarks and Guardrails
- Section 3 Freeing Ports
- Section 4 Ventilators
- Section 5 Permanent Gangways

CHAPTER 19 EQUIPMENT NUMBER AND EQUIPMENT

- Section 1 General
- Section 2 Equipment Number

CHAPTER 20 MACHINERY

- Section 1 General
- Section 2 Internal Combustion Engines
- Section 3 Boiler and Pressure Vessels
- Section 4 Auxiliaries and Piping Arrangement
- Section 5 General Requirements of Electrical Equipment
- Section 6 Earthing
- Section 7 Protective Devices of Electrical Equipment
- Section 8 Source of Electrical Power
- Section 9 Cables
- Section 10 Distribution
- Section 11 Control Gears
- Section 12 Explosion-Protected Electrical Equipment
- Section 13 Emergency Stopping Device
- Section 14 Machinery and Electrical Equipment of Tank Barges
- Section 15 Spare Parts
- Section 16 Tests

CHAPTER 21 PONTOON BARGES

- Section 1 General
- Section 2 Construction
- Section 3 Peak Construction

CHAPTER 22 TANK BARGES

- Section 1 General
- Section 2 Structural Members in Cargo Oil Spaces

CHAPTER 23 BARGES INTENDED TO BE CLASSIFIED AS RESTRICTED SERVICES

- Section 1 General
- Section 2 Barges Intended to be Classified as Coasting Service
- Section 3 Barges Intended to be Classified as Smooth Water Service

RULES FOR THE CLASSIFICATION OF DREDGERS

CHAPTER 1 GENERAL

- Section 1 General
- Section 2 Classification
- Section 3 Definitions

CHAPTER 2 REGISTRATION AND CLASSIFICATION SURVEYS

- Section 1 General
- Section 2 Classification Survey During Construction
- Section 3 Periodical Survey

CHAPTER 3 LONGITUDINAL STRENGTH

- Section 1 Longitudinal Strength

CHAPTER 4 SHELL PLATING AND DECKS

- Section 1 Shell Plating
- Section 2 Decks

CHAPTER 5 INTERNAL FRAMES

- Section 1 Transverse Framing System
- Section 2 Longitudinal Framing System

CHAPTER 6 PILLARS AND TRUSSES

- Section 1 General
- Section 2 Scantling of Pillars
- Section 3 Trusses

CHAPTER 7 WATERTIGHT BULKHEADS AND DEEP TANK

- Section 1 Arrangement of Watertight Bulkheads
- Section 2 Construction of Watertight Bulkheads
- Section 3 Deep Tank Construction
- Section 4 Fittings of Deep Tanks

CHAPTER 8 SUPERSTRUCTURE AND DECK HOUSE

- Section 1 General
- Section 2 Superstructure End Bulkheads
- Section 3 Access Opening in Superstructure End Bulkheads
- Section 4 Deck House Construction

CHAPTER 9 HATCHWAYS, DECK OPENINGS AND OTHER EQUIPMENT

- Section 1 General
- Section 2 Hatchways
- Section 3 Companionway and Other Deck Openings
- Section 4 Bulwarks and Guardrails
- Section 5 Freeing Ports
- Section 6 Ventilators
- Section 7 Companion Way

CHAPTER 10 HOPPER TYPE DREDGERS

- Section 1 General
- Section 2 Construction and Arrangement
- Section 3 Longitudinal Strength
- Section 4 Shell Plating and Deck
- Section 5 Transverse Framing System
- Section 6 Longitudinal Framing System
- Section 7 Transverse Ring
- Section 8 Hopper Well Structure

CHAPTER 11 EQUIPMENT

- Section 1 Anchor, Chain and Rope

CHAPTER 12 DREDGER REGISTERED WITH RESTRICTED SERVICES

- Section 1 General
- Section 2 Vessel Registered with Coastal Service
- Section 3 Dredger Registered with Smooth Water Service

CHAPTER 13 MACHINERY OF DREDGERS

- Section 1 Machinery and Dredging Equipment of Non Self-propelled dredgers
- Section 2 Machinery Installations of Self-propelled dredgers

(ANNEX)

- Annex 1 Guidance for the Assignment of Reduced Freeboards for Dredgers

RULES FOR THE CLASSIFICATION OF UNDERWATER VEHICLES

CHAPTER 1 GENERAL

- Section 1 General
- Section 2 Drawings and Documents
- Section 3 Tests and Trials
- Section 4 Marking

CHAPTER 2 CLASSIFICATION OF SUBMERSIBLE

- Section 1 Classification Registry
- Section 2 Classification Survey during Construction
- Section 3 Classification Survey after Construction

CHAPTER 3 PERIODICAL AND OTHER SURVEY

- Section 1 Kinds of Surveys
- Section 2 Performance of Survey

CHAPTER 4 DESIGN REQUIREMENTS

- Section 1 General
- Section 2 Environmental Conditions
- Section 3 Hatches, Doors and Access Ports
- Section 4 Equipment
- Section 5 Corrosion Protection

CHAPTER 5 PRESSURE HULL

- Section 1 General
- Section 2 Design Principles
- Section 3 Materials and Weldings
- Section 4 Principles of Manufacture and Construction
- Section 5 Calculations

CHAPTER 6 EXTERNAL STRUCTURE

- Section 1 General

CHAPTER 7 DIVING AND BUOYANCY TANKS AND TRIMMING DEVICES

- Section 1 General
- Section 2 Principles of Design and Construction
- Section 3 Materials, Manufacture and Calculations

CHAPTER 8 PRESSURE VESSELS AND APPARATUS

- Section 1 General
- Section 2 Compression Chambers and Diving Bells
- Section 3 Pressure Vessels and Apparatus and Gas Bottles

CHAPTER 9 PIPING SYSTEMS, PUMPS AND COMPRESSORS

- Section 1 General
- Section 2 Principles of Design and Construction
- Section 3 Materials, Manufacture and Calculations

CHAPTER 10 CONTROL SYSTEMS FOR DEPTH, TRIM, POSITIVE AND NEGATIVE BUOYANCY

- Section 1 General
- Section 2 Principles of Design and Construction

CHAPTER 11 PROPULSION AND MANOEUVRING EQUIPMENT

- Section 1 General
- Section 2 Principles of Design and Construction

CHAPTER 12 ELECTRIC EQUIPMENT

- Section 1 General
- Section 2 Design Principles

Section 3 Power Supply

CHAPTER 13 AUTOMATION, COMMUNICATION, NAVIGATING AND LOCATING EQUIPMENT

Section 1 General

Section 2 Automation Equipment

Section 3 Control System

Section 4 Communication Equipment

Section 5 Navigating and Locating Equipment

CHAPTER 14 LIFE SUPPORT SYSTEMS

Section 1 General

Section 2 Design Principles

Section 3 Air Supply

Section 4 Monitoring Equipment

Section 5 Emergency Thermal Protection

CHAPTER 15 FIRE PROTECTION AND FIRE EXTINGUISHING

Section 1 General

Section 2 Structural Fire Protection

Section 3 Fire Surveillance

Section 4 Fire Extinguishing Systems

CHAPTER 16 RESCUE SYSTEM

Section 1 General

Section 2 Design Principles

CHAPTER 17 LAUNCH, RECOVERY AND MATING EQUIPMENT

Section 1 General

Section 2 Design Principles

Section 3 Materials

Section 4 Principles of Manufacture and Construction

Section 5 Calculations

CHAPTER 18 REMOTE-OPERATED VEHICLES (ROVs)

Section 1 General

CHAPTER 19 TOURIST SUBMERSIBLES

Section 1 General

RULES FOR THE CLASSIFICATION OF FRP SHIPS

CHAPTER 1 GENERAL

- Section 1 General
- Section 2 Definitions
- Section 3 Hull Construction and Equipment

CHAPTER 2 CLASS SURVEYS

- Section 1 General
- Section 2 Classification Survey during Construction
- Section 3 Classification Survey after Construction

CHAPTER 3 MATERIALS

- Section 1 General
- Section 2 FRP Materials
- Section 3 FRP

CHAPTER 4 MOULDING

- Section 1 General
- Section 2 Laminating and Moulding
- Section 3 Additional Procedure for Hand Lay-up Method
- Section 4 Additional Procedure for Spray Lay-up Method
- Section 5 Additional Procedure for Sandwich Construction
- Section 6 Bonding and Fastening
- Section 7 Bonded Connections
- Section 8 Coating

CHAPTER 5 LONGITUDINAL STRENGTH

- Section 1 Longitudinal Strength

CHAPTER 6 SHELL LAMINATES

- Section 1 General
- Section 2 Keels
- Section 3 Shell Laminates for Midship Part
- Section 4 Shell Laminates for End Parts
- Section 5 Side shell Laminates in way of Superstructures
- Section 6 Local Strength of Shell Laminates

CHAPTER 7 DECKS

- Section 1 General
- Section 2 Minimum thickness of Deck Laminates
- Section 3 Local Compensation of Deck

CHAPTER 8 FRAMES

- Section 1 General
- Section 2 Construction
- Section 3 Spacing of Frames

Section 4 Frames

CHAPTER 9 BOTTOM CONSTRUCTION

- Section 1 General
- Section 2 Centre Girders
- Section 3 Side Girders
- Section 4 Floors
- Section 5 Bottom Longitudinals, etc.
- Section 6 Double Bottoms
- Section 7 Construction of Strengthened Bottom Forward
- Section 8 Hat-type Construction

CHAPTER 10 BEAMS

- Section 1 Beams

CHAPTER 11 UNDER-DECK GIRDERS AND PILLARS

- Section 1 Under-deck Girders
- Section 2 Pillars

CHAPTER 12 WATERTIGHT BULKHEADS

- Section 1 Arrangement of Watertight Bulkheads
- Section 2 Construction of Watertight Bulkheads

CHAPTER 13 DEEP TANKS

- Section 1 General
- Section 2 Bulkhead Laminates of Deep Tanks
- Section 3 Provisions for Deep Tanks

CHAPTER 14 MACHINERY SPACES

- Section 1 General
- Section 2 Construction under Main Engines

CHAPTER 15 SUPERSTRUCTURES AND DECKHOUSES

- Section 1 General
- Section 2 Construction, etc.

CHAPTER 16 HATCHWAY OPENINGS, MACHINERY OPENINGS AND OTHER DECK OPENINGS

- Section 1 General
- Section 2 Hatchway Openings
- Section 3 Machinery Openings
- Section 4 Companionway Openings and Other Deck Openings

CHAPTER 17 BULWARKS, GUARDRAILS, FREEING ARRANGEMENT, SIDE OPENINGS, SCUTTLES, VENTILATORS AND GANGWAYS

- Section 1 General

CHAPTER 18 MACHINERY

- Section 1 General

Section 2 Installation of Propulsion Machinery, Fuel Oil Tank and Earthing

RULES FOR THE CLASSIFICATION OF FLOATING DOCKS

CHAPTER 1 GENERAL

- Section 1 General
- Section 2 Classification Registry
- Section 3 Definition

CHAPTER 2 CLASSIFICATION SURVEY

- Section 1 Classification Surveys during Construction
- Section 2 Classification Survey after Construction
- Section 3 Periodical Survey and Occasional Survey
- Section 4 Cooperation for Surveys

CHAPTER 3 GENERAL ARRANGEMENT

- Section 1 General Arrangement

CHAPTER 4 FREEBOARD AND STABILITY

- Section 1 Freeboard
- Section 2 Stability

CHAPTER 5 HULL STRUCTURES

- Section 1 General
- Section 2 Longitudinal Strength
- Section 3 Transverse Strength
- Section 4 Structural Detail and Local Strength

CHAPTER 6 MACHINERY AND INSTRUMENTATION

- Section 1 Machinery
- Section 2 Indicator System

CHAPTER 7 FIRE PROTECTION AND EXTINGUISHING

- Section 1 General
- Section 2 Fire Protection
- Section 3 Fire-Extinguishing

RULES FOR THE CLASSIFICATION OF HIGH SPEED AND LIGHT CRAFTS

PART 1 CLASSIFICATION AND SURVEYS

CHAPTER 1 CLASSIFICATION

- Section 1 General
- Section 2 Classification Survey during Construction
- Section 3 Classification Survey after Construction

CHAPTER 2 PERIODICAL AND OTHER SURVEYS

- Section 1 General

PART 2 MATERIALS AND WELDING

CHAPTER 1 MATERIALS

Section 1 General

CHAPTER 2 WELDING

Section 1 General

Section 2 Welding of Aluminium Alloys

PART 3 HULL STRUCTURES

CHAPTER 1 DESIGN PRINCIPLES

Section 1 Definitions

Section 2 General

Section 3 Approval of Plans and Documents

Section 4 Subdivision and Arrangement

CHAPTER 2 DESIGN LOADS

Section 1 General

Section 2 Accelerations

Section 3 Sea Pressures

Section 4 Hull Girder Loads

CHAPTER 3 STRUCTURE PRINCIPLES IN STEEL

Section 1 General

Section 2 Materials and welding

Section 3 Manufacturing and Inspection

Section 4 Hull Girder Strength

Section 5 Platings

Section 6 Stiffeners

Section 7 Transverses and Girders

Section 8 Pillars

CHAPTER 4 STRUCTURE PRINCIPLES IN ALUMINIUM ALLOY

Section 1 General

Section 2 Materials and Welding

Section 3 Material Protection

Section 4 Hull Girder Strength

Section 5 Platings

Section 6 Stiffeners

Section 7 Transverses and Girders

Section 8 Pillars

CHAPTER 5 STRUCTURE PRINCIPLES IN FRP

Section 1 General

Section 2 Materials

Section 3 Manufacturing

- Section 4 Hull Girder Strength
- Section 5 Sandwich Panels
- Section 6 Single Skin Construction
- Section 7 Transverses and Girders

PART 4 HULL EQUIPMENT

CHAPTER 1 RUDDERS

- Section 1 General
- Section 2 Rudder Force
- Section 3 Rudder Torque
- Section 4 Rudder Strength Calculation
- Section 5 Rudder Stocks
- Section 6 Rudder Plates, Rudder Frames and Rudder Main Pieces
- Section 7 Couplings between Rudder Stocks and Main Pieces
- Section 8 Bearings of Rudder Stocks
- Section 9 Rudder Accessories

CHAPTER 2 HULL APPENDAGES

- Section 1 General
- Section 2 Materials and Workmanship
- Section 3 Arrangement of Appendages
- Section 4 Design Loads and Supporting Structure
- Section 5 Rudder Posts
- Section 6 Shaft Brackets
- Section 7 Foils
- Section 8 Waterjets

CHAPTER 3 EQUIPMENT NUMBER AND EQUIPMENT

- Section 1 General
- Section 2 Structural Arrangement for Anchoring Equipment
- Section 3 Equipment Number
- Section 4 Anchors
- Section 5 Anchor Chain Cables
- Section 6 Wire Ropes

CHAPTER 4 HATCHWAYS, WINDOWS AND OTHER OPENINGS

- Section 1 Hatchways and Other Deck Openings
- Section 2 Bulwarks, Freeing Ports, Side Scuttles, Ventilators
- Section 3 Windows

PART 5 MACHINERY INSTALLATIONS

CHAPTER 1 GENERAL

- Section 1 General

CHAPTER 2 AUXILIARIES AND PIPING ARRANGEMENT

- Section 1 General

- Section 2 Bilge and Drainage Systems
- Section 3 Air, Sounding and Filling Pipes
- Section 4 Ship-side Valves and Overboard Discharges
- Section 5 Fuel Oil System
- Section 6 Lubricating Oil System
- Section 7 Cooling Water System
- Section 8 Ventilation Systems

CHAPTER 3 PRIME MOVERS, POWER TRANSMISSION SYSTEMS AND LIFT DEVICES, ETC.

- Section 1 General

PART 6 ELECTRICAL EQUIPMENT AND CONTROL SYSTEMS

CHAPTER 1 ELECTRICAL EQUIPMENT

- Section 1 General
- Section 2 Electrical Equipment

CHAPTER 2 CONTROL SYSTEMS

- Section 1 General
- Section 2 Automatic and Remote Control Systems

PART 7 FIRE PROTECTION, DETECTION AND EXTINCTION

CHAPTER 1 FIRE PROTECTION

- Section 1 General
- Section 2 Structural Fire Protection
- Section 3 Additional Requirements for High Speed Passenger Craft
- Section 4 Additional Requirements for High Speed Cargo Craft
- Section 5 Additional Requirements for Craft and Cargo Spaces intended for the Carriage of Dangerous Goods

CHAPTER 2 FIRE DETECTION AND EXTINCTION

- Section 1 General
- Section 2 Fire Detection and Extinction
- Section 3 Additional Requirements for High Speed Passenger Craft
- Section 4 Additional Requirements for High Speed Cargo Craft
- Section 5 Additional Requirements for Craft and Cargo Spaces intended for the Carriage of Dangerous Goods

RULES FOR THE CLASSIFICATION OF TOWING SURVEY OF BARGES AND TUGBOATS

CHAPTER 1 GENERAL

- Section 1 General

CHAPTER 2 STRUCTURE AND EQUIPMENT

- Section 1 Tugboats
- Section 2 Barges

CHAPTER 3 TOWING ARRANGEMENTS

Section 1 Towing Arrangements and Resistances

CHAPTER 4 SURVEY OF TOWING

Section 1 Survey of Towing

RULES FOR THE CLASSIFICATION OF SHIPS USING LOW-FLASHPOINT FUELS

CHAPTER 1 GENERAL

Section 1 General

CHAPTER 2 GOAL AND FUNCTIONAL REQUIREMENTS

Section 1 Goal

Section 2 Functional requirements

CHAPTER 3 GENERAL REQUIREMENTS

Section 1 Goal

Section 2 Risk assessment

Section 3 Limitation of explosion consequences

CHAPTER 4 CLASSIFICATION SURVEYS

Section 1 General

Section 2 Classification

Section 3 Periodical Surveys

CHAPTER 5 SHIP DESIGN AND ARRANGEMENT

Section 1 Goal

Section 2 Functional requirements

Section 3 Arrangement of fuel tanks

Section 4 Machinery space concepts

Section 5 Gas safe machinery space

Section 6 ESD-protected machinery space

Section 7 Location and protection of fuel piping

Section 8 Fuel preparation room

Section 9 Bilge systems

Section 10 Drip trays

Section 11 Arrangement of entrances and other opening in enclosed spaces

Section 12 Airlocks

CHAPTER 6 FUEL CONTAINMENT SYSTEM

Section 1 Goal

Section 2 Functional requirements

Section 3 General requirements

Section 4 Liquefied gas fuel containment

Section 5 Portable liquefied gas fuel tanks

Section 6 CNG fuel containment

- Section 7 Pressure relief system
- Section 8 Loading limit for liquefied gas fuel tanks
- Section 9 Maintaining of fuel storage condition
- Section 10 Atmosphere control within the fuel containment system
- Section 11 Atmosphere control within the fuel hold spaces systems other than Type C independent tanks
- Section 12 Environmental control of spaces surrounding type C independent tanks
- Section 13 Inerting
- Section 14 Inert gas production and storage on board

CHAPTER 7 MATERIAL AND GENERAL PIPE DESIGN

- Section 1 Goal
- Section 2 Functional requirements
- Section 3 Pipe design
- Section 4 Materials

CHAPTER 8 BUNKERING AND FUEL SUPPLY

- Section 1 Goal
- Section 2 Functional requirements
- Section 3 Bunkering station
- Section 4 Manifold
- Section 5 Bunkering system

CHAPTER 9 FUEL SUPPLY TO CONSUMERS

- Section 1 Goal
- Section 2 Functional requirements
- Section 3 Redundancy of fuel supply
- Section 4 Safety functions of gas supply system
- Section 5 Fuel distribution outside of machinery space
- Section 6 Fuel supply to consumers in gas-safe machinery spaces
- Section 7 Fuel supply to consumers in ESD-protected machinery spaces
- Section 8 Design of ventilated duct, outer pipe against inner pipe gas leakage
- Section 9 Compressors and pumps

CHAPTER 10 POWER GENERATION INCLUDING PROPULSION AND OTHER GAS CONSUMER

- Section 1 Goal
- Section 2 Functional requirements
- Section 3 Internal combustion engines of piston type
- Section 4 Main and auxiliary boilers, gas turbine
- Section 5 Gas turbines

CHAPTER 11 FIRE SAFETY

- Section 1 Goal
- Section 2 Functional requirements
- Section 3 Fire protection
- Section 4 Fire extinction
- Section 5 Water spray system

Section 6 Dry chemical powder fire-extinguishing system

Section 7 Fire detection and alarm system

CHAPTER 12 EXPLOSION PREVENTION

Section 1 Goal

Section 2 Functional requirements

Section 3 General requirements

Section 4 Area classification

Section 5 Hazardous area zone

CHAPTER 13 VENTILATION

Section 1 Goal

Section 2 Functional requirements

Section 3 General requirements

Section 4 Tank connection space

Section 5 Machinery space

Section 6 Fuel preparation room

Section 7 Bunkering station

Section 8 Ducts and double pipes

CHAPTER 14 ELECTRICAL INSTALLATIONS

Section 1 Goal

Section 2 Functional requirements

Section 3 General requirements

CHAPTER 15 CONTROL, MONITORING AND SAFETY SYSTEMS

Section 1 Goal

Section 2 Functional requirements

Section 3 General requirements

Section 4 Bunkering and liquefied gas fuel tank monitoring

Section 5 Bunkering control

Section 6 Gas compressor monitoring

Section 7 Gas engine monitoring

Section 8 Gas detection

Section 9 Fire detection

Section 10 Ventilation

Section 11 Safety functions of fuel supply systems

CHAPTER 16 MANUFACTURE, WORKMANSHIP AND TESTING

Section 1 General

Section 2 General test regulations and specifications

Section 3 Welding of metallic materials and non-destructive testing for the fuel containment system

Section 4 Other regulations for construction in metallic materials

Section 5 Testing

Section 6 Welding, post-weld heat treatment and non-destructive testing

Section 7 Testing regulations

3.6 Contents of Other Guidance

GUIDANCE RELATING TO THE RULES FOR THE CLASSIFICATION OF STEEL BARGES

CHAPTER 1 GENERAL

- Section 1 Definitions
- Section 2 General

CHAPTER 4 LONGITUDINAL STRENGTH

- Section 1 General

CHAPTER 5 SHELL PLATING

- Section 4 Shell Plating for End Parts
- Section 6 Local Compensation of Shell Plating

CHAPTER 10 BEAMS

- Section 2 Deck Load

CHAPTER 14 WATERTIGHT BULKHEADS

- Section 1 Arrangement

CHAPTER 18 BULWARKS, FREEING PORTS, VENTILATORS AND PERMANENT GANGWAYS

- Section 2 Bulwarks and Guardrails
- Section 3 Freeing Ports

CHAPTER 20 MACHINERY

- Section 2 Internal Combustion Engines
- Section 4 Auxiliaries and Piping Arrangement
- Section 5 General Requirements of Electrical Equipment
- Section 6 Earthing
- Section 7 Protective Devices of Electrical Equipment
- Section 8 Source of Electrical Power
- Section 9 Cables
- Section 11 Control Gears
- Section 16 Testing

CHAPTER 23 BARGES INTENDED TO BE CLASSIFIED AS RESTRICTED SERVICES

- Section 2 Barges Intended to be classified as Coastal Service
- Section 3 Barges Intended to be classified as Smooth Water Service

〈ANNEX〉

- Annex 1 Special Requirements for Pusher-Barges

GUIDANCE RELATING TO THE RULES FOR THE CLASSIFICATION OF UNDERWATER VEHICLES

CHAPTER 1 GENERAL

- Section 1 General
- Section 3 Tests and Trials

CHAPTER 2 CLASSIFICATION OF SUBMERSIBLE

- Section 1 Classification Registry
- Section 2 Classification Survey during Construction
- Section 3 Classification Survey after Construction

CHAPTER 4 DESIGN REQUIREMENTS

- Section 2 Environmental Conditions

CHAPTER 5 PRESSURE HULL

- Section 2 Design Principles
- Section 3 Materials and Weldings
- Section 4 Principles of Manufacture and Construction
- Section 5 Calculations

CHAPTER 12 ELECTRIC EQUIPMENT

- Section 2 Design Principles

CHAPTER 13 AUTOMATION, COMMUNICATION, NAVIGATING AND LOCATING EQUIPMENT

- Section 2 Automation Equipment

CHAPTER 16 RESCUE SYSTEM

- Section 1 General

CHAPTER 18 REMOTE-OPERATED VEHICLES (ROVs)

- Section 1 Registry
- Section 2 Survey during Construction
- Section 3 Survey after Construction
- Section 4 Periodical and other surveys
- Section 5 Documents and drawings for approval
- Section 6 Design and Construction

CHAPTER 19 TOURIST SUBMERSIBLES

- Section 1 General
- Section 2 Classification Registry
- Section 3 Periodical and Other Survey

⟨ANNEX⟩

- Annex 1 Calculation and Pressure Hulls under External Pressure
- Annex 2 Design and Construction for Submersible with GRP
- Annex 3 Stabilities of Submersibles

GUIDANCE RELATING TO THE RULES FOR THE CLASSIFICATION OF FRP SHIPS

CHAPTER 1 GENERAL

- Section 1 General
- Section 2 Definitions
- Section 3 Hull Construction and Equipments

CHAPTER 2 CLASS SURVEYS

- Section 1 General
- Section 2 Classification Survey during Construction

CHAPTER 3 MATERIALS

- Section 1 General
- Section 2 FRP Materials
- Section 3 FRP

CHAPTER 4 MOULDING

- Section 6 Bonding and Fastening
- Section 7 Bonded Connections

CHAPTER 5 LONGITUDINAL STRENGTH

- Section 1 Longitudinal Strength

CHAPTER 7 DECKS

- Section 2 Minimum thickness of Deck Laminates

CHAPTER 10 BEAMS

- Section 1 Beams

CHAPTER 12 WATERTIGHT BULKHEADS

- Section 2 Construction of Watertight Bulkheads

CHAPTER 13 DEEP TANKS

- Section 2 Bulkhead Laminates of Deep Tanks

CHAPTER 18 MACHINERY

- Section 2 Installation of Propulsion Machinery, Fuel Oil Tank and Earthing

⟨ANNEX⟩

- Annex 1 Test and Inspections of Materials for Primary Structures
- Annex 2 Test and Inspection of Sandwich constructions Materials
- Annex 3 Banding Strength Test of Bulkhead Laminates of Structural Plywood

GUIDANCE RELATING TO THE RULES FOR THE CLASSIFICATION OF FLOATING DOCKS

CHAPTER 1 GENERAL

Section 1 General

CHAPTER 4 FREEBOARD AND STABILITY

Section 2 Stability

〈ANNEX〉 GUIDANCE FOR DOCK GATES

1. General
2. Classification Surveys
3. Stability
4. Structure and Strength
5. Opening and Closing Equipment of Dock Gate

GUIDANCE RELATING TO THE RULES FOR THE CLASSIFICATION OF HIGH SPEED AND LIGHT CRAFTS

PART 1 CLASSIFICATION AND SURVEYS

CHAPTER 1 CLASSIFICATION

Section 1 General

PART 3 HULL STRUCTURES

CHAPTER 1 DESIGN IN GENERAL

Section 2 General

〈ANNEX〉

- Annex 3-1 Guidance for the Direct Strength Assessment
- Annex 3-2 Guidance for Buckling Strength Calculation

CHAPTER 2 DESIGN LOADS

Section 4 Hull Girder Loads

CHAPTER 4 STRUCTURE PRINCIPLES IN ALUMINIUM ALLOY

Section 4 Hull Girder Strength

CHAPTER 5 STRUCTURE PRINCIPLES IN FRP

Section 1 General

PART 4 HULL EQUIPMENT

CHAPTER 3 EQUIPMENT NUMBER AND EQUIPMENT

Section 1 General

PART 5 MACHINERY SYSTEM

CHAPTER 1 GENERAL

Section 1 General

CHAPTER 2 AUXILIARIES AND PIPING ARRANGEMENT

- Section 1 General
- Section 2 Bilge pumping system
- Section 4 Ship-side Valves and Overboard Discharges
- Section 7 Cooling Water System

CHAPTER 3 PRIME MOVERS, POWER TRANSMISSION SYSTEMS AND LIFT DEVICES, ETC.

- Section 1 General

PART 6 ELECTRICAL EQUIPMENT AND CONTROL SYSTEMS

CHAPTER 1 ELECTRICAL EQUIPMENT

- Section 1 General
- Section 2 Electric Equipment

CHAPTER 2 CONTROL SYSTEMS

- Section 1 General

PART 7 FIRE PROTECTION, DETECTION AND EXTINCTION

CHAPTER 1 FIRE PROTECTION

- Section 2 Structural Fire Protection
- Section 3 Additional Requirements for High Speed Passenger Craft

CHAPTER 2 FIRE DETECTION AND EXTINCTION

- Section 2 Fire Detection and Extinction
- Section 3 Additional Requirements for High Speed Passenger Craft
- Section 4 Additional Requirements for High Speed Cargo Craft

**GUIDANCE RELATING TO THE RULES FOR THE CLASSIFICATION OF SHIPS USING
LOW-FLASHPOINT FUELS**

CHAPTER 1 GENERAL

- Section 1 General

CHAPTER 2 GOAL AND FUNCTIONAL REQUIREMENTS

- Section 2 Functional requirements

CHAPTER 3 GENERAL REQUIREMENTS

- Section 3 Limitation of explosion consequences

CHAPTER 4 CLASSIFICATION SURVEYS

- Section 3 Periodical Surveys

CHAPTER 5 SHIP DESIGN AND ARRANGEMENT

- Section 4 Machinery space concepts
- Section 7 Location and protection of fuel piping
- Section 8 Fuel preparation room

CHAPTER 6 FUEL CONTAINMENT SYSTEM

- Section 3 General requirements
- Section 4 Liquefied gas fuel containment
- Section 7 Pressure relief system
- Section 8 Loading limit for liquefied gas fuel tanks
- Section 9 Maintaining of fuel storage condition

CHAPTER 7 MATERIAL AND GENERAL PIPE DESIGN

- Section 3 Pipe design
- Section 4 Materials

CHAPTER 8 BUNKERING AND FUEL SUPPLY

- Section 3 Bunkering station

CHAPTER 9 FUEL SUPPLY TO CONSUMERS

- Section 4 Safety functions of gas supply system
- Section 5 Fuel distribution outside of machinery space
- Section 6 Fuel supply to consumers in gas-safe machinery spaces

CHAPTER 10 POWER GENERATION INCLUDING PROPULSION AND OTHER GAS CONSUMER

- Section 3 Internal combustion engines of piston type

CHAPTER 11 FIRE SAFETY

- Section 3 Fire protection

CHAPTER 12 EXPLOSION PREVENTION

- Section 4 Area classification
- Section 5 Hazardous area zone

CHAPTER 13 VENTILATION

- Section 3 General requirements
- Section 5 Machinery space
- Section 8 Ducts and double pipes

CHAPTER 14 ELECTRICAL INSTALLATIONS

- Section 3 General requirements

CHAPTER 15 CONTROL, MONITORING AND SAFETY SYSTEMS

- Section 3 General requirements
- Section 4 Bunkering and liquefied gas fuel tank monitoring
- Section 8 Gas detection
- Section 10 Ventilation

CHAPTER 16 MANUFACTURE, WORKMANSHIP AND TESTING

- Section 1 General
- Section 2 General test regulations and specifications
- Section 3 Welding of metallic materials and non-destructive testing for the fuel containment system

- Section 4 Other regulations for construction in metallic materials
- Section 5 Testing
- Section 7 Testing regulations

<ANNEX>

- Annex 1 Requirements for equipment used for low-flashpoint fuel supply systems
- Annex 2 Standard for the use of limit state methodologies in the design of fuel containment systems of novel configuration
- Annex 3 Risk assessment
- Annex 4 High manganese austenitic steel for Cryogenic Service
- Annex 5 Requirements for Ships Using Methyl/Ethyl Alcohol as Fuel
- Annex 6 Requirements for Ships Using LPG as Fuel
- Annex 7 Requirements for Ships Using Ammonia as Fuel

GUIDANCE FOR APPROVAL OF MANUFACTURING PROCESS AND TYPE APPROVAL, ETC.

CHAPTER 1 GENERAL

- Section 1 General
- Section 2 Definitions

CHAPTER 2 APPROVAL OF MANUFACTURING PROCESS

- Section 1 General
- Section 2-1 Rolled Steels
- Section 2-2 Semi Finished Products for Rolled Steels
- Section 2-3 Other Semi Finished Products
- Section 2-4 Rolled Steels intended for welding with high heat input
- Section 2-5 YP47 Steel Plates
- Section 2-6 Hull Structural Steels with Improved Fatigue Properties
- Section 2-7 High Strength Steels for Welded Structures
- Section 2-8 Brittle Crack Arrest Steels
- Section 2-9 High manganese austenitic steels
- Section 3 Steel Tubes and Pipes
- Section 4-1 Castings
- Section 4-2 Steel Forgings
- Section 5 Crankshafts under special requirements
- Section 6-1 Aluminium Alloys
- Section 6-2 Aluminium/steel transition joints
- Section 7-1 Copper Alloy Castings
- Section 7-2 Copper and Copper Alloy Tubes
- Section 8 Special Cast Iron Valves
- Section 9 Anchors
- Section 10-1 Marine Chains
- Section 10-2 Marine Chain Accessories
- Section 10-3 Offshore Chains and Chain Accessories
- Section 11 Wire Rope
- Section 12 Synthetic Fibre Ropes

- Section 13 FRP Ships
- Section 14 Boiler and Pressure Vessel

CHAPTER 3 TYPE APPROVAL

- Section 1 General
- Section 2 Welding Materials
- Section 3-1 Anti-corrosive Paints
- Section 3-2 Non-slip Paints
- Section 4 Acid Resisting Paints
- Section 5 Loading Instruments
- Section 6 High Holding Power Anchors and Super High Holding Power Anchors
- Section 7-1 Emergency Towing Arrangements
- Section 7-2 Equipment for mooring at SPM
- Section 8 Diesel Engines
- Section 9-1 Crankcase Explosion Relief Valves
- Section 9-2 Explosion Relief Devices for Reciprocating Internal Combustion Engines Using Gas as Fuel
- Section 10 Crankcase Oil Mist Detection Arrangements
- Section 11 Exhaust Gas Turbochargers
- Section 12 Hydraulic Motors and Hydraulic Pumps
- Section 13 Air Compressors
- Section 14 Safety Valves
- Section 15 Machinery and Equipment for Ships
- Section 16 Plastic Piping System
- Section 17 Flexible Hose Assembly
- Section 18 Mechanical Joints
- Section 19 Air Pipe Automatic Closing Devices
- Section 20 Level Indicators
- Section 21 Electrical Equipment and Cables
- Section 22 Cable Laying
- Section 23 Automatic and Remote Control Systems
- Section 24 Equipment related to Ventilation Systems in Oil Tankers
- Section 25 Securing Devices
- Section 26 Fire Protection Materials
- Section 27 Materials for Refrigerated Chambers and Oil-impervious composition
- Section 28 Materials of Reinforced Plastics
- Section 29 Water Level Detection and Alarm System
- Section 30 Protective Coating Systems
- Section 31 LED lighting fitting
- Section 32 Corrosion Resistant Steels
- Section 33 Protective Coating Systems for Cargo Oil Tanks
- Section 34 Fiber Reinforced Plastic Gratings
- Section 35 Ballast Water Management System
- Section 36 Acoustic Insulation Materials
- Section 37 Busbar Trunking Systems
- Section 38 Cable Transit Seal Systems for watertight bulkhead and decks

- Section 39 Electric Power Converters
- Section 40 Composite Material Pressure Vessels for Fuel Containment of Compressed Hydrogen Gas
- Section 41 Watertight bulkheads or deck pipe penetrations on passenger ships

CHAPTER 4 DESIGN APPROVAL

- Section 1 General
- Section 2 Loading Instrument Program
- Section 3 Container Lashing calculation program
- Section 4 Lashing calculation program for semi-standardized and non-standardized cargo

CHAPTER 5 APPROVAL OF QUALITY ASSURANCE SYSTEM

- Section 1 General
- Section 2 Assessment
- Section 3 Approval
- Section 4 Requirements of Quality Assurance System

CHAPTER 6 MANUFACTURER APPROVAL

- Section 1 General
- Section 2 Assessment
- Section 3 Approval

〈ANNEX〉

1. Approval Certificate for Manufacturing Process
2. Type Approval Certificate
3. Design Approval Certificate
4. Approval Certificate for Quality Assurance System
5. Approval Certificate for Manufacturer
6. Application Form for Approval

GUIDANCE FOR FLOATING STRUCTURES

CHAPTER 1 GENERAL

- Section 1 General

CHAPTER 2 CLASSIFICATION SURVEYS

- Section 1 General
- Section 2 Periodical Surveys

CHAPTER 3 HULL STRUCTURES

- Section 1 Materials and Structures

CHAPTER 4 MOORING AND ANCHORING, ETC.

- Section 1 Standard for Ship's Facilities
- Section 2 Load Lines, etc.

CHAPTER 5 FIRE PROTECTION

- Section 1 General

CHAPTER 6 MACHINERY INSTALLATIONS

Section 1 General

CHAPTER 7 ELECTRICAL INSTALLATIONS

Section 1 General

CHAPTER 8 FIRE-FIGHTING APPLIANCES

Section 1 General

GUIDANCE FOR FREIGHT CONTAINERS

CHAPTER 1 GENERAL

Section 1 General

Section 2 Definitions

CHAPTER 2 CONSTRUCTION AND CERTIFICATION OF FREIGHT CONTAINERS

Section 1 General

Section 2 Approval of Manufacturing Process

Section 3 Type Approval Inspection

Section 4 Production Unit Inspection

Section 5 Certificate and Identification

Section 6 General Cargo Containers

Section 7 Thermal Containers

Section 8 Tank Containers

〈Appendix〉

Appendix 2-1 Approval Certificate for Manufacturing Process

Appendix 2-2 Certificate for Type Approval Test of Freight Container

Appendix 2-3 Certificate of Inspection on Articles for Ship use of Approved Type

CHAPTER 3 GUIDANCE FOR APPROVAL OF CONTAINER(TIR CONVENTION)

Section 1 General

Section 2 Type Approval

Section 3 Individual Approval

Section 4 Production Unit Inspection

〈Appendix〉

Appendix 3-1 Regulations on Technical Conditions

Appendix 3-2 Application of Container Inspection for TIR

Appendix 3-3 Certificate of Approval by Design Type

Appendix 3-4 Certificate of Approval granted at a Stage subsequent to manufacturer

Appendix 3-5 Approval Plate

Appendix 3-6 Freight Container Production Certificate

GUIDANCE FOR SINGLE POINT MOORING

CHAPTER 1 CLASSIFICATION REGISTRY AND SURVEYS

- Section 1 Classification Registry
- Section 2 Testing During Construction
- Section 3 Surveys After Construction

CHAPTER 2 MATERIALS AND WELDING

- Section 1 Materials
- Section 2 Welding and Fabrication
- Section 3 Weld Design

CHAPTER 3 DESIGN OF MOORING SYSTEM

- Section 1 Site and Environmental Conditions
- Section 2 Design Loads
- Section 3 Structural Design and Stability
- Section 4 Mooring and Anchoring

CHAPTER 4 EQUIPMENT AND SYSTEMS

- Section 1 Cargo or Product Transfer Systems
- Section 2 Ancillary Systems and Equipment
- Section 3 Hazardous Areas and Electrical Installations
- Section 4 Safety Provisions

GUIDANCE FOR SHIPS CARRYING CNG IN BULK

CHAPTER 1 GENERAL

- Section 1 General

CHAPTER 2 CLASSIFICATION SURVEYS

- Section 1 General
- Section 2 Periodical Surveys

CHAPTER 3 STRUCTURES AND EQUIPMENTS

- Section 1 General
- Section 2 Ship Survival Capability and Location of Cargo Tanks
- Section 3 Ship Arrangements
- Section 4 Cargo Containment
- Section 5 Process Pressure Vessels and Liquid, Vapour, and Pressure Piping Systems
- Section 6 Materials of Construction
- Section 7 Cargo Pressure/Temperature Control
- Section 8 Cargo Tank and Cargo Hold Vent Systems
- Section 9 Environmental Control
- Section 10 Electrical Installations
- Section 11 Fire Protection and Fire Extinction
- Section 12 Mechanical Ventilation in the Cargo Area
- Section 13 Instrumentation (Gauging, Gas Detection)
- Section 14 Filling Limits for Cargo Tanks
- Section 15 Use of Cargo as Fuel
- Section 16 Operating Requirements

GUIDANCE FOR RECREATIONAL CRAFTS

CHAPTER 1 GENERAL

- Section 1 General
- Section 2 Essential Requirements

CHAPTER 2 CLASSIFICATION SURVEYS

- Section 1 General
- Section 2 Kinds and Due Range of Surveys
- Section 3 Scope of Surveys

CHAPTER 3 MATERIALS

- Section 1 General
- Section 2 Metal Material and Welding
- Section 3 Wood
- Section 4 FRP Material and Moulding

CHAPTER 4 STRUCTURES

- Section 1 General
- Section 2 Pressure Adjusting Factors
- Section 3 Design Pressure
- Section 4 Scantling of Plating
- Section 5 Requirements for Stiffening
- Section 6 Structural Arrangement

CHAPTER 5 STABILITY AND BUOYANCY

- Section 1 General
- Section 2 Non-sailing Crafts of Hull Length Greater than or Equal to 6 m
- Section 3 Sailing Crafts of Hull Length Greater than or Equal to 6 m
- Section 4 Crafts of Hull Length Less than 6 m
- Section 5 Maximum Load Capacity

CHAPTER 6 HULL EQUIPMENT

- Section 1 Protection against Falling Overboard and Reboarding
- Section 2 Windows, Portlights, Hatches, Deadlights and Doors
- Section 3 Watertight Cockpits and Quick-draining Cockpits
- Section 4 Rudders
- Section 5 Anchoring, Mooring and Towing – Strong Points

CHAPTER 7 STEERING SYSTEM

- Section 1 General
- Section 2 Hydraulic Steering System
- Section 3 Field of Vision from Steering Position

CHAPTER 8 MACHINERY INSTALLATIONS

- Section 1 Engine and Engine Spaces
- Section 2 Propulsion System

- Section 3 Starting System
- Section 4 Sea Water and Drainage Piping Systems
- Section 5 Discharge Prevention and Installations Facilitating the Delivery Ashore of Waste
- Section 6 Fuel System
- Section 7 Ventilation

CHAPTER 9 ELECTRICAL EQUIPMENT

- Section 1 Direct Current System
- Section 2 Alternating Current System
- Section 3 Navigation Lights

CHAPTER 10 LPG SYSTEM FOR DOMESTIC USE

- Section 1 General
- Section 2 Pressure Reduction System
- Section 3 Gas Supply Line System
- Section 4 Gas Appliances
- Section 5 Location and Installation of Gas Cylinders
- Section 6 Ventilation
- Section 7 Ducts and Flues for Air Intake and Combustion-product Discharge
- Section 8 Electrical Devices for Ignition Protection
- Section 9 Gas Installation System Tests
- Section 10 Owner's Manual

CHAPTER 11 FIRE PROTECTION AND FIRE EXTINCTION

- Section 1 Fire Protection
- Section 2 Fire Fighting Equipment
- Section 3 Others

CHAPTER 12 ESSENTIAL REQUIREMENTS FOR EXHAUST EMISSIONS FROM PROPULSION ENGINES

- Section 1 General
- Section 2 Essential Requirements

CHAPTER 13 ESSENTIAL REQUIREMENTS FOR NOISE EMISSIONS

- Section 1 General
- Section 2 Essential Requirements

GUIDANCE FOR WIG CRAFT (WING-IN-GROUND EFFECT CRAFT)

Chapter 1 GENERAL

Chapter 2 CLASSIFICATION AND SURVEYS

Chapter 3 STRUCTURES

Chapter 4 EQUIPMENT

Chapter 5 STABILITY AND SUBDIVISION

Chapter 6 MACHINERY

Chapter 7 ELECTRICAL EQUIPMENT AND CONTROL SYSTEMS

Chapter 8 FIRE PROTECTION

Chapter 9 FIRE EXTINCTION

Chapter 10 EVACUATION INSTALLATIONS

Chapter 11 SPECIAL INSTALLATIONS

<Annex>

Annex 1 FIRE PROTECTION TEST PROCEDURE

Annex 2 EMERGENCY EVACUATION TEST PROCEDURE

GUIDANCE FOR LARGE YACHTS

PART 1 CLASSIFICATION AND SURVEYS

CHAPTER 1 CLASSIFICATION

Section 1 General

Section 2 Classification Survey during Construction

Section 3 Classification Survey after Construction

CHAPTER 2 PERIODICAL AND OTHER SURVEYS

Section 1 General

PART 2 MATERIALS AND WELDING

CHAPTER 1 MATERIALS

Section 1 General

CHAPTER 2 WELDING

Section 1 General

Section 2 Welding of Aluminium Alloys

PART 3 HULL STRUCTURES

CHAPTER 1 DESIGN PRINCIPLES

Section 1 Definitions

Section 2 General

Section 3 Approval of Plans and Documents

Section 4 Subdivision and Arrangement

CHAPTER 2 DESIGN LOADS

Section 1 General

Section 2 Accelerations

Section 3 Sea Pressures

Section 4 Hull Girder Loads

CHAPTER 3 STRUCTURE PRINCIPLES IN STEEL

- Section 1 General
- Section 2 Materials and Welding
- Section 3 Manufacturing and Inspection
- Section 4 Hull Girder Strength
- Section 5 Platings
- Section 6 Stiffeners
- Section 7 Transverses and Girders
- Section 8 Pillars

CHAPTER 4 STRUCTURE PRINCIPLES IN ALUMINIUM ALLOY

- Section 1 General
- Section 2 Materials and Welding
- Section 3 Material Protection
- Section 4 Hull Girder Strength
- Section 5 Platings
- Section 6 Stiffeners
- Section 7 Transverses and Girders
- Section 8 Pillars

CHAPTER 5 STRUCTURE PRINCIPLES IN FRP

- Section 1 General
- Section 2 Materials
- Section 3 Manufacturing
- Section 4 Hull Girder Strength
- Section 5 Sandwich Panels
- Section 6 Single Skin Construction
- Section 7 Transverses and Girders

PART 4 HULL EQUIPMENT

CHAPTER 1 RUDDERS

- Section 1 General
- Section 2 Rudder Force
- Section 3 Rudder Torque
- Section 4 Rudder Strength Calculation
- Section 5 Rudder Stocks
- Section 6 Rudder Plates, Rudder Frames and Rudder Main Pieces
- Section 7 Couplings between Rudder Stocks and Main Pieces
- Section 8 Bearings of Rudder Stock
- Section 9 Rudder Accessories

CHAPTER 2 EQUIPMENT NUMBER AND EQUIPMENT

- Section 1 General
- Section 2 Structural Arrangement for Anchoring Equipment
- Section 3 Equipment Number

- Section 4 Anchors
- Section 5 Anchor Chain Cables
- Section 6 Wire Ropes
- Section 7 Intact Stability

CHAPTER 3 HATCHWAYS, WINDOWS AND OTHER OPENINGS

- Section 1 Hatchways and Other Deck Openings
- Section 2 Bulwarks, Freeing Ports, Side Scuttles, Ventilators
- Section 3 Windows

PART 5 MACHINERY INSTALLATIONS

CHAPTER 1 GENERAL

- Section 1 General

CHAPTER 2 AUXILIARIES AND PIPING ARRANGEMENT

- Section 1 General
- Section 2 Bilge and Drainage Systems
- Section 3 Air, Sounding and Filling Pipes
- Section 4 Ship-side Valves and Overboard Discharges
- Section 5 Fuel Oil System
- Section 6 Lubricating Oil System
- Section 7 Cooling Water System
- Section 8 Ventilation Systems

CHAPTER 3 PRIME MOVERS, POWER TRANSMISSION SYSTEMS, ETC.

- Section 1 General

PART 6 ELECTRICAL EQUIPMENT AND CONTROL SYSTEMS

CHAPTER 1 ELECTRICAL EQUIPMENT

- Section 1 General
- Section 2 Electrical Equipment

CHAPTER 2 CONTROL SYSTEMS

- Section 1 General
- Section 2 Automatic and Remote Control Systems

PART 7 FIRE PROTECTION AND EXTINCTION

CHAPTER 1 FIRE PROTECTION

- Section 1 General
- Section 2 Structural Fire Protection
- Section 3 Ventilation System

CHAPTER 2 FIRE DETECTION AND EXTINCTION

- Section 1 General
- Section 2 Fire Detection and TV Monitoring System
- Section 3 Fire Extinction System

GUIDANCE FOR FUEL CELL SYSTEMS ON BOARD OF SHIPS

CHAPTER 1 GENERAL

Section 1 General

CHAPTER 3 STRUCTURES AND INSTALLATION

Section 1 General

Section 2 Design Principles for Fuel Cell Power Installations

Section 3 Fire Safety

Section 4 Electrical System

Section 5 Control, Monitoring and Safety System

Section 6 Fuel Cells Associated Auxiliaries

Section 7 Manufacture, Workmanship and Testing

GUIDANCE FOR SHIPS FOR NAVIGATION IN ICE

CHAPTER 1 STRENGTHENING FOR NAVIGATION IN ICE

Section 1 General

Section 2 Ice strengthening

Section 3 Hull Structural Design

Section 4 Rudder and Steering Arrangements

Section 5 Engine Output

Section 6 Propulsion Machinery

Section 7 Miscellaneous Machinery Requirements

CHAPTER 2 SHIPS FOR NAVIGATION IN POLAR WATERS

Section 1 Polar Class Descriptions and Application

Section 2 Structural Requirements for Polar Class Ships

Section 3 Machinery Requirements for Polar Class Ships

CHAPTER 3 SHIPS FOR ICE BREAKING CAPABILITY FOR NAVIGATION IN POLAR WATERS

Section 1 General

Section 2 Strengthening of Arctic class ships and Icebreakers

Section 3 Rudder

Section 4 Machinery Installations

Section 5 Subdivision and Stability

CHAPTER 4 WINTERIZATION

Section 1 General

Section 2 Material for hull construction at low temperatures

Section 3 Winterization M – Materials for equipment and components at low temperatures

Section 4 Winterization E3(t) – Main component and sub-component

Section 5 Winterization E2(t) – Main component and sub-component

Section 6 Winterization E1(t) – Main component and sub-component

Section 7 Winterization S – Stability due to ice accretion

Section 8 Winterization D – Alternative design

Section 9 Winterization IR – Ice removal arrangements

Section 10 Ship specific requirements

<ANNEX>

Annex 1 Strengthening for navigation in Ice.

Annex 2 Ice Load cases for propeller and the shape of the propeller ice torque excitation for the ships strengthened for navigation in ice and polar class ships

GUIDANCE FOR APPROVAL OF RISK-BASED SHIP DESIGN

CHAPTER 1 GENERAL

Section 1 General

Section 2 Definitions

CHAPTER 2 STAKEHOLDERS AND QUALIFICATION

Section 1 General

Section 2 Design Team

Section 3 Approval Team

CHAPTER 3 APPROVAL PROCESS

Section 1 Approval Process

Section 2 Preliminary approval

Section 3 Final Approval

CHAPTER 4 SURVEY REQUIREMENTS

Section 1 Survey Requirements

CHAPTER 5 RISK EVALUATION CRITERIA

Section 1 General

Section 2 Types of Risk

CHAPTER 6 DOCUMENTATION REQUIREMENTS

Section 1 General

Section 2 Documentation to be Prepared and Exchanged

Section 3 Documentation Form

<ANNEX>

Annex 1 Risk Acceptance Criteria

Annex 2 Form of Preliminary Approval Certificate

GUIDANCE FOR STRENGTH ASSESSMENT OF MEMBRANE-TYPE LNG TANKS UNDER SLOSHING LOADS

CHAPTER 1 GENERAL

Section 1 Application

Section 2 Symbols and definitions

Section 3 Documentation

CHAPTER 2 ASSESSMENT OF DESIGN SLOSHING LOAD

- Section 1 Sloshing analysis condition
- Section 2 Sloshing analysis – Model test
- Section 4 Sloshing simulation using CFD

CHAPTER 3 STRENGTH ASSESSMENT OF LNG CCS

- Section 1 General
- Section 2 Configuration of CCS
- Section 3 Analysis based on static load
- Section 4 Methods of assessment
- Section 5 Acceptance criteria
- Section 6 Advanced dynamic analysis

GUIDANCE FOR LNG FUEL READY SHIPS

CHAPTER 1 GENERAL

- Section 1 General
- Section 2 Notation

CHAPTER 2 REQUIREMENTS FOR LEVEL OF LNG FUEL READY

- Section 1 General
- Section 2 Level of Preparing Generic Design
- Section 3 Level of Installing Parts of Systems
- Section 4 Survey

GUIDANCE ON STRENGTH ASSESSMENT OF CONTAINERSHIPS CONSIDERING THE WHIPPING EFFECT

CHAPTER 1 GENERAL

- Section 1 General
- Section 2 Analysis Procedure

CHAPTER 2 SELECTION OF DESIGN WAVE AND DOMINANT SEA STATE

- Section 1 General
- Section 2 Design Wave Selection
- Section 3 Dominant Sea State Selection

CHAPTER 3 HYDRO-ELASTIC SIMULATION

- Section 1 General
- Section 2 Hydro-Elastic Simulation In Time Domain

CHAPTER 4 EVALUATION OF HULL GIRDER STRENGTH CONSIDERING THE WHIPPING EFFECT

- Section 1 General
- Section 2 Estimation Of Whipping Contribution By Design Wave Method
- Section 3 Estimation Of Whipping Contribution By Design Sea State Method
- Section 4 Estimation Of Whipping Contribution And Ultimate Hull Girder Strength

GUIDANCE FOR STRUCTURAL STRENGTH ASSESSMENT OF PUMP TOWER OF LNG CARRIERS

CHAPTER 1 GENERAL

- Section 1 General
- Section 2 Introduction
- Section 3 Equivalency
- Section 4 Documents

CHAPTER 2 LOADS ON PUMP TOWER

- Section 1 General
- Section 2 Loads

CHAPTER 3 STRUCTURAL STRENGTH ASSESSMENT

- Section 1 Structure modeling
- Section 2 Boundary conditions
- Section 3 Strength assessment

GUIDANCE FOR NOISE AND VIBRATION

CHAPTER 1 GENERAL

- Section 1 General
- Section 2 Approval of plans and documents

CHAPTER 2 CLASSIFICATION SURVEYS

- Section 1 General
- Section 2 Classification Survey
- Section 3 Periodical Surveys
- Section 4 Occasional Surveys

CHAPTER 3 NOISE

- Section 1 General
- Section 2 Measurement Procedure
- Section 3 Measurement Location
- Section 4 Measurement Conditions
- Section 5 Criteria

CHAPTER 4 VIBRATION

- Section 1 General
- Section 2 Measurement Procedure
- Section 3 Measurement Location
- Section 4 Measurement Conditions
- Section 4 Criteria

GUIDANCE FOR SHIFTLIFT AND TRANSFER SYSTEMS

CHAPTER 1 GENERAL

- Section 1 General
- Section 2 Classification Regulations
- Section 3 Certification requirements

CHAPTER 2 STRUCTURAL DESIGN

- Section 1 Structural design criteria

CHAPTER 3 TESTING

- Section 1 Test criteria

GUIDANCE FOR BATTERY SYSTEMS ON BOARD OF SHIPS

CHAPTER 1 GENERAL

- Section 1 General
- Section 2 Drawings and Data

CHAPTER 2 CLASSIFICATION SURVEYS

- Section 1 General
- Section 2 Periodical Surveys
- Section 3 Tests and inspections
- Section 4 Tests after installation

CHAPTER 3 CONSTRUCTION AND EQUIPMENT

- Section 1 General
- Section 2 System Design
- Section 3 Electric Power Converters
- Section 4 Fire Protection and Fire Extinction
- Section 5 Cooling
- Section 6 Monitoring and Safety Systems
- Section 7 Risk Assessment

GUIDANCE FOR MARITIME CYBER SECURITY SYSTEM

CHAPTER 1 GENERAL

- Section 1 General

CHAPTER 2 SURVEYS

- Section 1 General
- Section 2 Initial Surveys for Company
- Section 3 Initial Surveys for Ship
- Section 4 Surveys for Certification Maintenance
- Section 5 Remote Cyber Security Surveys

CHAPTER 3 REQUIREMENTS FOR CS SYSTEM OF THE COMPANY

- Section 1 General
- Section 2 Company Cyber Security Compliance 0
- Section 3 Company Cyber Security Compliance 1
- Section 4 Company Cyber Security Compliance 2

Section 5 Company Cyber Security Compliance 3

CHAPTER 4 REQUIREMENTS FOR CS SYSTEM OF THE SHIP

- Section 1 General
- Section 2 CS Ready
- Section 3 Ship Cyber Security Compliance 0 or CS0
- Section 4 Ship Cyber Security Compliance 1 or CS1
- Section 5 Ship Cyber Security Compliance 2 or CS2
- Section 6 Ship Cyber Security Compliance 3 or CS3

GUIDANCE FOR FLOATING LNG BUNKERING TERMINAL

CHAPTER 1 GENERAL

- Section 1 General
- Section 2 Definitions

CHAPTER 2 CLASSIFICATION AND SURVEYS

- Section 1 General
- Section 2 Classification Survey
- Section 3 Surveys

CHAPTER 3 DESIGN CONDITION

- Section 1 General
- Section 2 Design Loads
- Section 3 Corrosion Control Means and Corrosion Margins
- Section 4 Risk Assessment

CHAPTER 4 MATERIALS AND WELDING

- Section 1 General

CHAPTER 5 HULL CONSTRUCTION AND EQUIPMENT

- Section 1 General
- Section 2 Survival Capability and Location of Cargo Tanks
- Section 3 Longitudinal Strength
- Section 4 Structural Design and Analysis of the Hull
- Section 5 Hull Arrangements
- Section 6 Hull Equipment

CHAPTER 6 POSITIONING SYSTEM

- Section 1 General
- Section 2 Mooring Analysis
- Section 3 Design of Mooring Lines, etc.
- Section 4 Mooring Equipment
- Section 5 Single Pint Mooring Systems
- Section 6 Anchor Holding Power

CHAPTER 7 MACHINERY INSTALLATIONS

- Section 1 General
- Section 2 Piping Systems for Cargo Tanks
- Section 3 Use of Natural Gas as Fuel

CHAPTER 8 ELECTRICAL EQUIPMENT AND CONTROL SYSTEMS

- Section 1 Hazardous Area
- Section 2 Electrical Equipment
- Section 3 Control Systems

CHAPTER 9 VENTILATION

- Section 1 General
- Section 2 Mechanical Ventilation in the Cargo Area

CHAPTER 10 FIRE PROTECTION, FIRE EXTINGUISHION AND MEANS OF ESCAPE

- Section 1 Fire Protection and Fire Extinguishment
- Section 2 Means of Escape

CHAPTER 11 PERSONNEL PROTECTION

- Section 1 Personnel Protection

CHAPTER 12 BUNKERING SYSTEM

- Section 1 General
- Section 2 Arrangement and Design of Bunkering Systems
- Section 3 Bunker Transfer Systems
- Section 4 Control, Monitoring and Safety Systems
- Section 5 Communication and Lighting Systems
- Section 6 Operation Requirements

GUIDANCE FOR APPROVAL OF SERVICE SUPPLIERS

CHAPTER 1 INTRODUCTION

- Section 1 General
- Section 2 Approval and Certification

CHAPTER 2 Approval of Service Suppliers listed in IACS URZ17)

- Section 1 Firms engaged in thickness measurements on ships or mobile offshore units(Z17 Annex1-1)
- Section 2 Firms engaged in tightness testing of closing appliances such as hatches, doors etc. with ultrasonic equipment (Z17 Annex 1-2)
- Section 3 Firms carrying out an in-water survey on ships and mobile offshore units by diver or Remotely Operated Vehicle(ROV) (Z17 Annex 1-3)
- Section 4 Firms engaged in inspection and maintenance of fire extinguishing equipment & systems and self contained breathing apparatus(Z17 Annex 1-4 & Annex 1-7)
- Section 5 Firms engaged in servicing life saving appliances(Z17 Annex 1-5 & Annex1-13)
- Section 6 Firms engaged in inspections and testing of radio communication equipment (Z17 Annex 1-6)
- Section 7 Firms engaged in examination of Ro-Ro ships bow, stern, side and inner doors

- (Z17 Annex 1-8)
- Section 8 Firms engaged in annual performance testing of Voyage Data Recorders(VDR) and simplified Voyage Data Recorders(S-VDR) (Z17 Annex 1-9)
- Section 9 Firms engaged in inspections of low location lighting systems using photo luminescent materials and evacuation guidance system used as an alternative to low-location lighting system (Z17 Annex 1-10)
- Section 10 Firms engaged in sound pressure level measurements of public address and general alarm systems on board ships(Z17 Annex 1-11)
- Section 11 Firms engaged in testing of coating system in accordance with IMO Res.MSC. 215(82) as amended and IACS UI SC223 and/or MSC. 288(87) as amended(Z17 Annex 1-12)
- Section 12 Firms engaged in measurements of Noise level Onboard Ships(Z17 Annex 1-14)
- Section 13 Firms engaged in tightness testing of primary and secondary barriers of gas carriers with membrane cargo containment systems for vessels in service(Z17 Annex 1-15)
- Section 14 Firms engaged in survey using Remote Inspection Techniques(RIT) as alternative means for Close-up Survey of the structure of ships and mobile offshore units(Z17 Annex 1-16)
- Section 15 Firms engaged in cable transit seal systems inspection of on ships and mobile offshore units(Z17 Annex 1-17)
- Section 16 Firms engaged in Commissioning Testing of Ballast Water Management Systems (BWMS) units (Z17 Annex 1-18)

CHAPTER 3 Approval of Service Suppliers listed in IACS UR W35

- Section 1 Independent NDT company or NDT department/section that forms a part of a shipbuilding company providing NDT services on ship and/or offshore components /structures)

CHAPTER 4 Approval of Service Suppliers not listed in IACS UR Z17

- Section 1 Firms engaged in vibration measurement in relation to habitability of ship
- Section 2 Firms engaged in visual and/or sample checks for preparation of inventory of hazardous materials(IHM)
- Section 3 Firms engaged in measurement of URN from ships

GUIDANCE FOR AUTONOMOUS SHIPS

CHAPTER 1 GENERAL

- Section 1 General
- Section 2 Operation Plan
- Section 3 Cybersecurity

CHAPTER 2 CLASS SURVEY

- Section 1 General
- Section 2 Classification Survey
- Section 3 Periodical Survey for Maintaining Registration

CHAPTER 3 AUTONOMOUS SYSTEMS AND AUTONOMOUS SHIPS

- Section 1 Configuration and Function of Autonomous Systems
- Section 2 Requirements for Autonomous Systems and Autonomous Ships

CHAPTER 4 RISK-BASED APPROVAL

- Section 1 General
- Section 2 Considerations when Approving Risk-based Design
- Section 3 Measures to Reduce Risk

GUIDANCE FOR DC DISTRIBUTION SYSTEMS

CHAPTER 1 GENERAL

- Section 1 General
- Section 2 Drawings and Data

CHAPTER 2 SYSTEM AND ELECTRICAL EQUIPMENT

- Section 1 System Design
- Section 2 Electrical Equipment

CHAPTER 3 CONTROL SYSTEMS

- Section 1 General
- Section 2 System Design

CHAPTER 4 CLASSIFICATION SURVEYS

- Section 1 General
- Section 2 Testing and Inspection
- Section 3 Testing and Inspection of DC Circuit-breaker

CHAPTER 5 RISK ASSESSMENT

- Section 1 General
- Section 2 Risk Assessment

GUIDANCE FOR COMPUTER-BASED SYSTEM CONFORMITY ASSESSMENT

CHAPTER 1 GENERAL

- Section 1 General
- Section 2 Assessment process

CHAPTER 2 COMPUTER-BASED SYSTEM CONFORMITY ASSESSMENT

- Section 1 General
- Section 2 Embedded software
- Section 3 Application software

<ANNEX>

- ANNEX 1 TEMPLATE

GUIDANCE FOR CONFORMITY CERTIFICATION OF MARITIME EQUIPMENT CYBER SECURITY

CHAPTER 1 GENERAL

- Section 1 General
- Section 2 Procedures for Certification

CHAPTER 2 COMMON REQUIREMENTS FOR EQUIPMENT CYBER SECURITY

- Section 1 General
- Section 2 Identification and authentication
- Section 3 Use Control
- Section 4 System Integrity
- Section 5 Data Confidentiality
- Section 6 Restricted Data Flow
- Section 7 Timely Response to Events
- Section 8 Resource Availability

CHAPTER 3 ADDITIONAL REQUIREMENTS FOR EQUIPMENT CYBER SECURITY

- Section 1 General
- Section 2 Additional Requirements for Software Application
- Section 3 Additional Requirements for Embedded Device
- Section 4 Additional Requirements for Host Device
- Section 5 Additional Requirements for Network Device

<Annex>

- ANNEX 1 MAPPING THE REQUIREMENTS TO SECURITY LEVEL

GUIDANCE FOR COMPOSITE PROPELLERS

CHAPTER 1 GENERAL

- Section 1 General
- Section 2 Approval procedure

CHAPTER 2 APPROVAL OF MANUFACTURING PROCESS

- Section 1 General
- Section 2 Plant audit
- Section 3 Approval test

CHAPTER 3 INDIVIDUAL PRODUCT

- Section 1 General
- Section 2 Drawing approval
- Section 3 Product inspection

**GUIDANCE OF HEAT TRANSFER ANALYSIS FOR SHIPS CARRYING LIQUEFIED GASES
IN BULK/SHIPS USING LIQUEFIED GASES AS FUELS**

CHAPTER 1 GENERAL

- Section 1 Application
- Section 2 Definitions
- Section 3 Summary of Guidances
- Section 4 Documentation

CHAPTER 2 HEAT TRANSFER ANALYSIS FOR MEMBRANE TYPE

- Section 1 Analytical Heat Transfer Analysis
- Section 2 FEM Heat Transfer Analysis

CHAPTER 3 HEAT TRANSFER ANALYSIS FOR INDEPENDENT TYPE A TANK

- Section 1 Analytical Heat Transfer Analysis
- Section 2 FEM Heat Transfer Analysis

CHAPTER 4 HEAT TRANSFER ANALYSIS FOR INDEPENDENT TYPE B TANK

- Section 1 Analytical Heat Transfer Analysis
- Section 2 FEM Heat Transfer Analysis

CHAPTER 5 HEAT TRANSFER ANALYSIS FOR INDEPENDENT TYPE C TANK

- Section 1 Analytical Heat Transfer Analysis
- Section 2 FEM Heat Transfer Analysis

GUIDANCE FOR INTEGRATED SOFTWARE PROCESS MANAGEMENT

CHAPTER 1 GENERAL

- Section 1 General

CHAPTER 2 TEST AND SURVEY

- Section 1 General

CHAPTER 3 SOFTWARE PROCESS

- Section 1 General
- Section 2 Roles and Responsibility of Stakeholder
- Section 3 ISPM Process

CHAPTER 4 PROJECT PROCESS

- Section 1 Management Process
- Section 2 Support Process

CHAPTER 5 SOFTWARE LIFE CYCLE PROCESS

- Section 1 Planning Process
- Section 2 Requirement and Development Process
- Section 3 Implementation Process
- Section 4 Transition Process
- Section 5 Maintenance Process

GUIDANCE FOR FATIGUE STRENGTH ASSESSMENT INCLUDING SPRINGING

CHAPTER 1 GENERAL

- Section 1 General
- Section 2 Assessment Procedure
- Section 3 Assessment conditions
- Section 4 Hydro-elastic simulation

CHAPTER 2 LINEAR SPRINGING ASSESSMENT

- Section 1 Calculation of stress transfer function and response spectrum
- Section 2 Linear springing assessment by direct method
- Section 3 Linear springing assessment by comparative method

CHAPTER 3 NONLINEAR SPRINGING ASSESSMENT

- Section 1 Nonlinear springing assessment by direct method
- Section 2 Nonlinear springing assessment by comparative method
- Section 3 Nonlinear springing assessment for low-speed blunt ships where vertical bending moment is significant

GUIDANCE FOR PREVENTION SYSTEMS OF POLLUTION FROM SHIPS

CHAPTER 1 ENVIRONMENTAL PROTECTION SYSTEM

- Section 1 General
- Section 2 Environmental Protection System (Phase 1)
- Section 3 Environmental Protection System (Phase 2)
- Section 4 Environmental Protection System (Phase 3)

CHAPTER 2 NITROGEN OXIDES EMISSION ABATEMENT SYSTEM

- Section 1 General
- Section 2 Selective Catalytic Reduction system (SCR)
- Section 3 Exhaust Gas Recirculation system(EGR)

CHAPTER 3 SULPHUR OXIDES EMISSION ABATEMENT SYSTEM

- Section 1 General
- Section 2 Exhaust Gas Cleaning system(EGC)
- Section 3 Exhaust Gas Cleaning system Ready ships
- Section 4 Ships using low sulphur fuel

CHAPTER 4 SHIPS SATISFYING ENERGY EFFICIENCY DESIGN INDEX(EEDI) PHASE 3

- Section 1 General

CHAPTER 5 WIND ASSISTED PROPULSION SYSTEMS

- Section 1 General
- Section 2 Survey
- Section 3 Basic requirements for Wind Assisted Propulsion Systems
- Section 4 Additional requirements for Wind Assisted Propulsion Systems

CHAPTER 6 HULL AIR LUBRICATION SYSTEM

- Section 1 General
- Section 2 Basic requirements for Hull Air Lubrication System
- Section 3 Additional requirements for Hull Air Lubrication System
- Section 4 Survey

GUIDANCE FOR RADIATED NOISE FROM SHIPS

CHAPTER 1 GENERAL

- Section 1 General
- Section 2 Plans and Documents

CHAPTER 2 CLASSIFICATION SURVEYS

- Section 1 General
- Section 2 Test and Inspection
- Section 3 Periodical Surveys
- Section 4 Occasional Surveys

CHAPTER 3 UNDERWATER NOISE

- Section 1 General
- Section 2 Instrumentation
- Section 3 Measurement Procedure
- Section 4 Measurement Condition
- Section 5 Data Post-processing
- Section 6 Criteria

CHAPTER 4 AIRBORNE NOISE

- Section 1 General
- Section 2 Instrumentation
- Section 3 Measurement Procedure
- Section 4 Measurement Condition
- Section 5 Data Post-processing
- Section 6 Criteria

GUIDANCE FOR REMOTE SURVEY

- Section 1 General
- Section 2 Requirements for equivalency
- Section 3 Scope and procedures
- Section 4 Information and Communication Technology (ICT)
- Section 5 Recording of evidence and reporting of survey

ANNEX

- Annex 1 Declaration of Master

GUIDANCE FOR REMOTE INSPECTION TECHNIQUES

CHAPTER 1 GENERAL

CHAPTER 2 QUALIFICATION OF SERVICE SUPPLIERS

CHAPTER 3 SURVEY USING RIT

CHAPTER 4 DATA

GUIDANCE FOR SHIPS DESIGNED TO PREVENT THE SPREAD OF INFECTIOUS DISEASE

- Section 1 General
- Section 2 Classification Surveys
- Section 3 Design Requirements

GUIDANCE FOR SMART SYSTEMS

CHAPTER 1 GENERAL

- Section 1 General
- Section 2 Class Notation

CHAPTER 2 CLASSIFICATION SURVEYS

- Section 1 Classification Surveys

CHAPTER 3 FUNCTIONAL REQUIREMENTS FOR SMART SYSTEMS

- Section 1 Smart Infrastructure
- Section 2 Structural Health Monitoring (SHM)
- Section 3 Machinery Health Monitoring (MHM)
- Section 2 Energy Efficiency Management (EEM)
- Section 3 Intelligent Navigation

CHAPTER 4 SCALABLE TECHNOLOGY

- Section 1 Virtual Reality (VR)
- Section 2 Augmented Reality (AR)

GUIDANCE FOR CYBER RESILIENCE OF SHIPS AND SYSTEMS

CHAPTER 1 GENERAL

- Section 1 General
- Section 2 Definitions and abbreviation
- Section 3 Risk assessment for exclusion of CBS from the application of requirements

CHAPTER 2 CYBER RESILIENCE OF SHIPS

- Section 1 General
- Section 2 Classification Survey
- Section 3 Goals and organization of requirements
- Section 4 Requirements for Cyber Resilience of ships
- Section 5 Requirements for Cyber Security Management System)

CHAPTER 3 CYBER RESILIENCE OF SYSTEMS AND EQUIPMENT

- Section 1 General
- Section 2 Survey of Systems and Equipment
- Section 3 Approval documents and data
- Section 4 System Requirements
- Section 5 Secure Development Lifecycle Requirements

Appendix 1 – Summary of requirements and documents for ships

Appendix 2 – Requirement for Cyber Security Management System of existing ships)

GUIDANCE FOR PHOTOVOLTAIC SYSTEMS ONBOARD SHIPS

CHAPTER 1 GENERAL

Section 1 General

Section 2 Drawings and Data for Approval and Onboard Retention)

CHAPTER 2 TESTS FOR PHOTOVOLTAIC SYSTEMS

Section 1 General

Section 2 Type Approval for Photovoltaic Systems

Section 3 Commissioning Test

CHAPTER 3 SYSTEMS AND EQUIPMENT)

Section 1 General

Section 2 System Design

Section 3 Electrical and Associated Installations

Section 4 Installation

GUIDANCE FOR APPROVAL OF ADDITIVE MANUFACTURING(3D PRINTING)

CHAPTER 1 GENERAL

Section 1 General

Section 2 Approval and Certification Process

CHAPTER 2 DESIGN REVIEW AND APPROVAL

Section 1 General

Section 2 Design Requirements

Section 3 Materials Requirements

CHAPTER 3 TYPE APPROVAL OF FEEDSTOCK

Section 1 General

Section 2 Feedstock Specification Approval

Section 3 Type Test

Section 4 Survey & Range of Approval

CHAPTER 4 APPROVAL OF MANUFACTURING PROCESS–PRODUCT(PART)

Section 1 General

Section 2 Additive Manufacturing Process Specification(AMPS)

Section 3 Plant Audit

Section 4 Approval Test

Section 5 Survey & Range of Approval

CHAPTER 5 APPROVAL OF MANUFACTURING PROCESS–ADDITIVELY MANUFACTURED METALLIC MATERIALS

- Section 1 General
- Section 2 Approval Test
- Section 3 Survey & Range of Approval

CHAPTER 6 APPROVAL FOR PRODUCT(PART)

- Section 1 General
- Section 2 Test and Inspection
- Section 3 Non-Conformance and Documentation

CHAPTER 7 APPROVAL FOR ADDITIVE MANUFACTURING REPAIR FACILITY

- Section 1 General
- Section 2 Repair Procedure Specification and Approval
- Section 3 Survey & Range of Approval

GUIDANCE FOR ANCHOR HANDLING APPLIANCE

CHAPTER 1 GENERAL

- Section 1 General

CHAPTER 2 CLASSIFICATION SURVEYS

- Section 1 General
- Section 2 Registration Surveys
- Section 3 Periodical Surveys
- Section 4 Occasional Surveys

CHAPTER 3 ANCHOR HANDLING APPLIANCE

- Section 1 Anchor Handling Winches and Associated Equipment
- Section 2 Wire
- Section 3 Machinery, Electrical Installations and Control Engineering Systems
- Section 4 Certification, Marking and Documentation

4. CONVERSION TABLE OF SI UNITS

Quantity	SI Unit	Other Unit	Remarks
mass	kg	t	1 t = 10 ³ kg
density (mass density)	kg/m ³	-	-
moment of inertia	kg - m ²	-	-
force	N	kgf	1 kgf = 9.81 N
moment (torque)	N - m	kgf - m	1 kgf - m = 9.81 N - m
stress	Pa or N/m ²	kgf/mm ²	1 kgf/mm ² = 9.81 N/mm ² = 9.81 MPa
pressure	Pa	kgf/cm ² or bar	1 kgf/cm ² = 0.981 bar = 98.1 kPa
work energy	J	kgf - m	1 kgf - m = 9.81 J
electric potential	J	kW - h	1 kW - h = 3.6 × 10 ⁶ J
power	W	PS	1 PS = 735.5 W
temperature	K or °C	C	x °C = (x + 273.15) K
quantity of heat	J	cal or kcal	1 kcal = 4.19 kJ
heat flow rate	W	kcal/h	1 kcal/h = 1.16 W
frequency	Hz	-	-
rotational frequency	s ⁻¹	min ⁻¹ (rpm)	rpm = 60 /s
velocity	m/s	knot	1 knot = 1852 m/h
plane angle	rad	° ; ' ; "	1° = $\frac{\pi}{180}$ rad

5. LOAD LINE MARKS

(1) Assignment of Load Line

The Society is authorized to assign Load Lines to vessels registered by the Korean Government and other Governments.

(2) Load Line Mark for Ocean Going Vessels without Timber Load Line

The centre of the ring is to be placed on each side of the ship at the middle of the length as defined in the International Convention on Load Lines, 1966. The ring, lines and letters are to be painted in white or yellow on a dark ground or in black on a light ground. They are also to be permanently marked on the sides of the ship as shown in **Fig 1**.

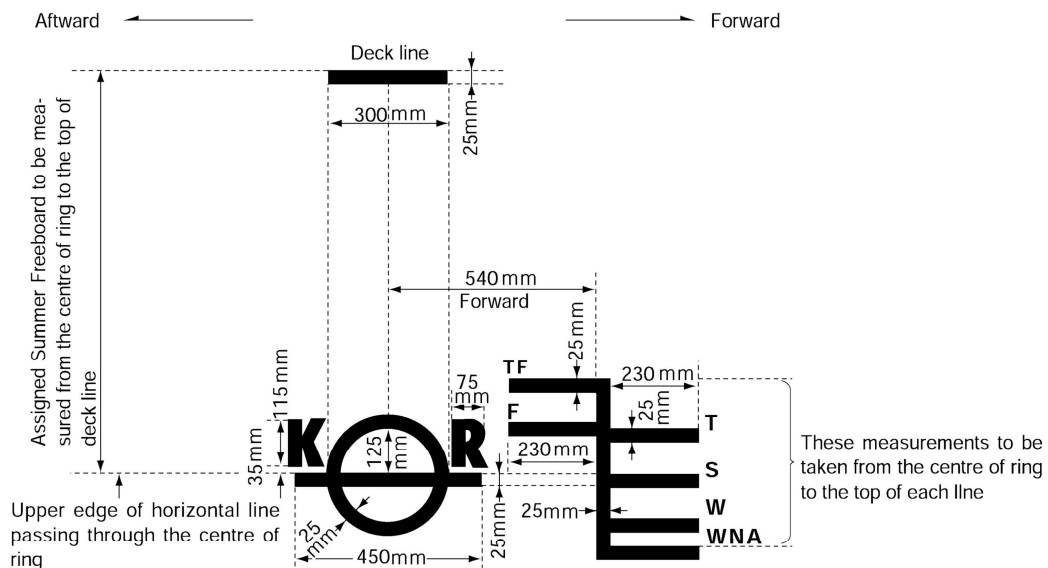
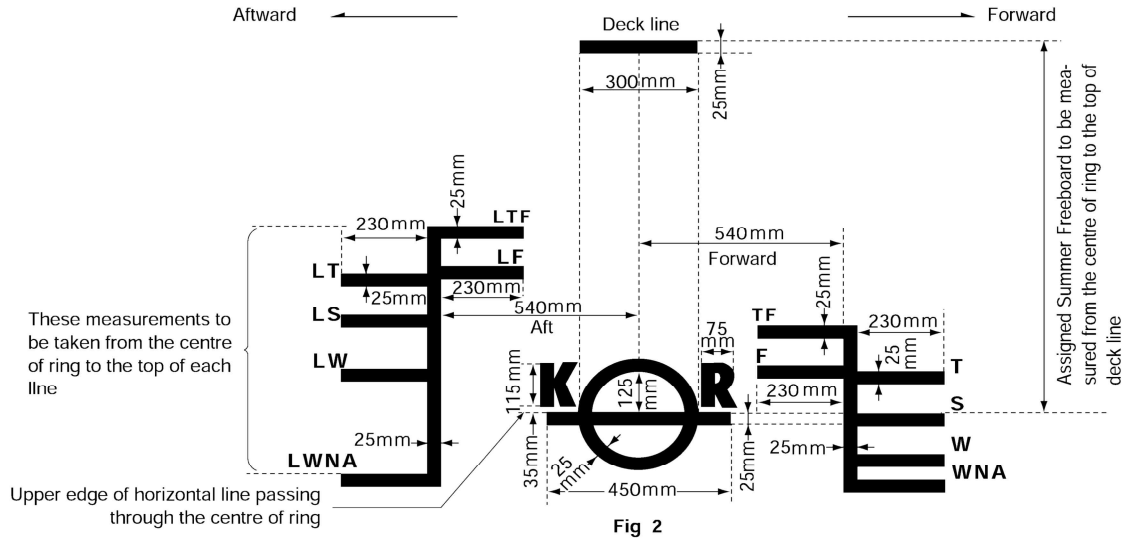

Fig 1

(3) Load Line Mark for Ocean Going Vessels with Timber Load Line

The centre of the ring is to be placed on each side of the ship at the middle of the length as defined in the International Convention on Load Lines, 1966. The ring, lines and letters are to be painted in white or yellow on a dark ground or in black on a light ground. They are also to be permanently marked on the sides of the ship as shown in **Fig 2**.



(4) For Korean flagged vessels which are over 12 m and for domestic voyage, the load line mark is to be as shown in Fig 3 Marking method refers to (2). However, for the vessels navigating solely on lakes and rivers sub-paragraph (5) may be applied.

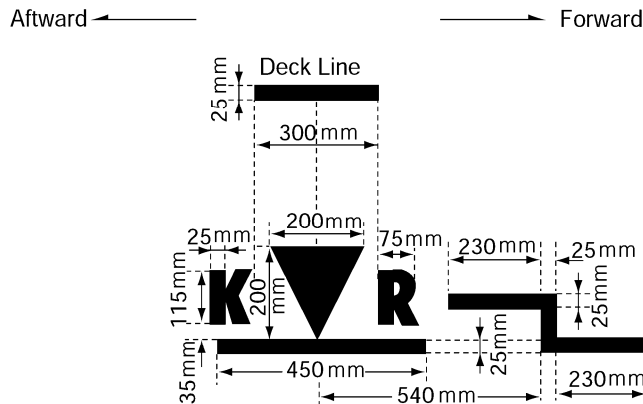

(5) For Korean flagged passenger vessels and dangerous cargo carriers which are less than 12 m in length and for domestic voyage, the load line mark is to be as shown in Fig 4 Marking method refers to (2).

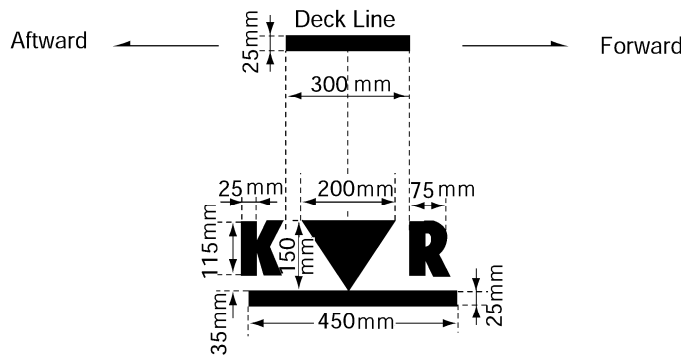

- (7) For Korean flagged high speed crafts which are less than 12 m in length and for domestic voyage, the load line mark is to be as shown in Fig 6 Marking method refers to (2).

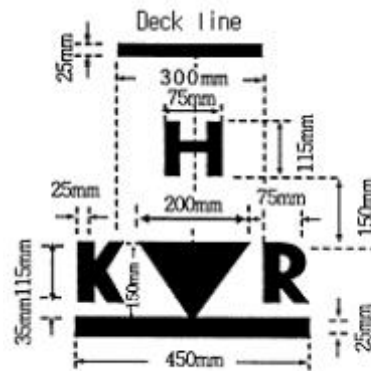

Fig 6

- (8) For Korean flagged high speed crafts which are over 12 m in length and for domestic voyage, the load line mark is to be as shown in Fig 7 Marking method refers to (2).

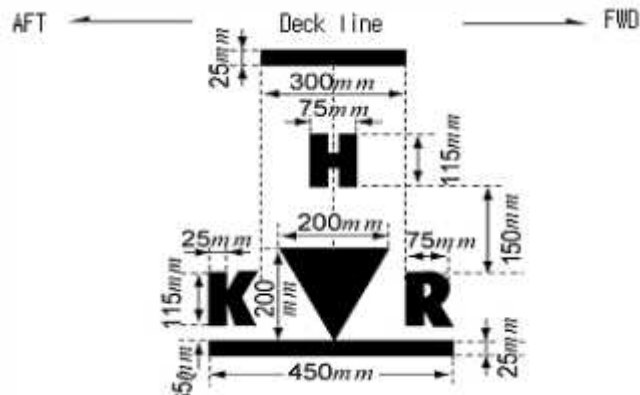

Fig 7

- (9) For high speed craft subject to 2000 HSC Code engaged in international voyage, the load line mark is to be as shown in Fig 8 Marking method refers to (2).

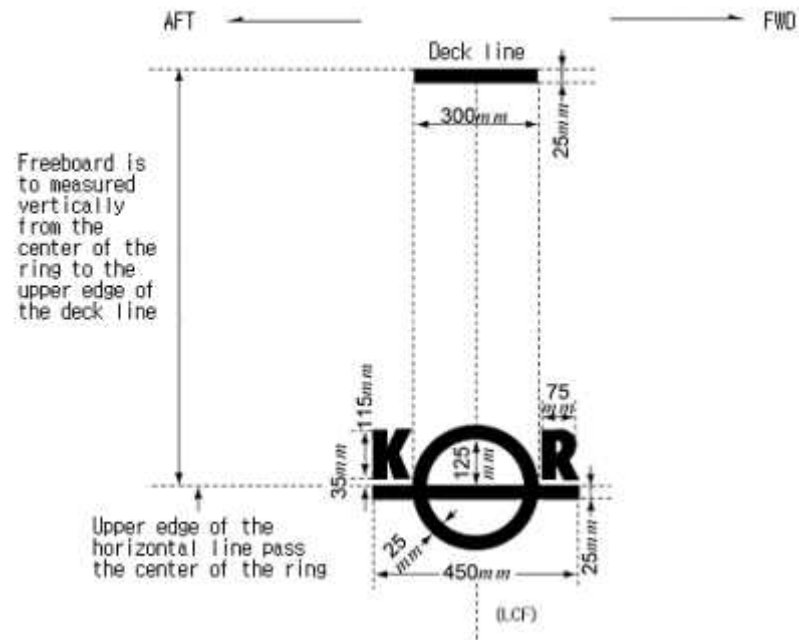

Fig 8

INTRODUCTION TO THE CLASSIFICATION TECHNICAL RULES

Published by

KR

36, Myeongji ocean city 9-ro, Gangseo-gu,
BUSAN, KOREA

TEL : +82 70 8799 7114

FAX : +82 70 8799 8999

Website : <http://www.krs.co.kr>

Copyright© 2026, KR

Reproduction of this Introduction in whole or in parts is
prohibited without permission of the publisher.